

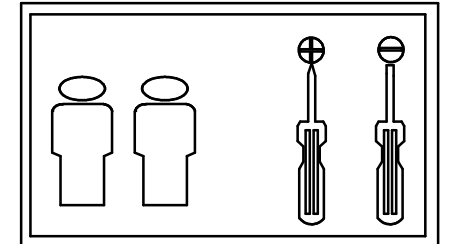







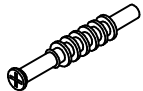

Inhalt - Contents - Contenu - Inhoud - contenuto - contenido-conteúdo - περιεχόμενο

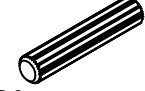
Milano 06 649

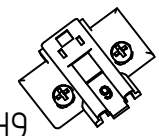
Schrank 4 Türen

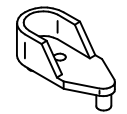
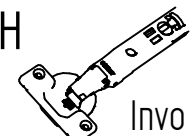

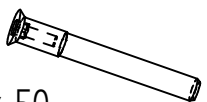
Beschlagbeutel:

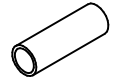
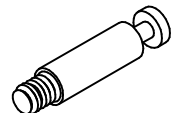
| | | | | | |
|---|---|---|---|---|--|
| A |  | B |  15 ohne Rand | C |  8 x 30 |
| | 16x | | 24 x | | 31 x |
| D |  3 x 16 | E |  Invo H9 | F |  |
| | 26 x | | 12 x | | 4 x |
| G |  | H |  Invo Kr.9 | I |  |
| | 4 x | | 12 x | | 20 x |
| J |  7 x 50 | K |  | M |  |
| | 21 x | | 3 x | | 4 x |
| N |  M4 | | | | |
| | 8 x | | | | |

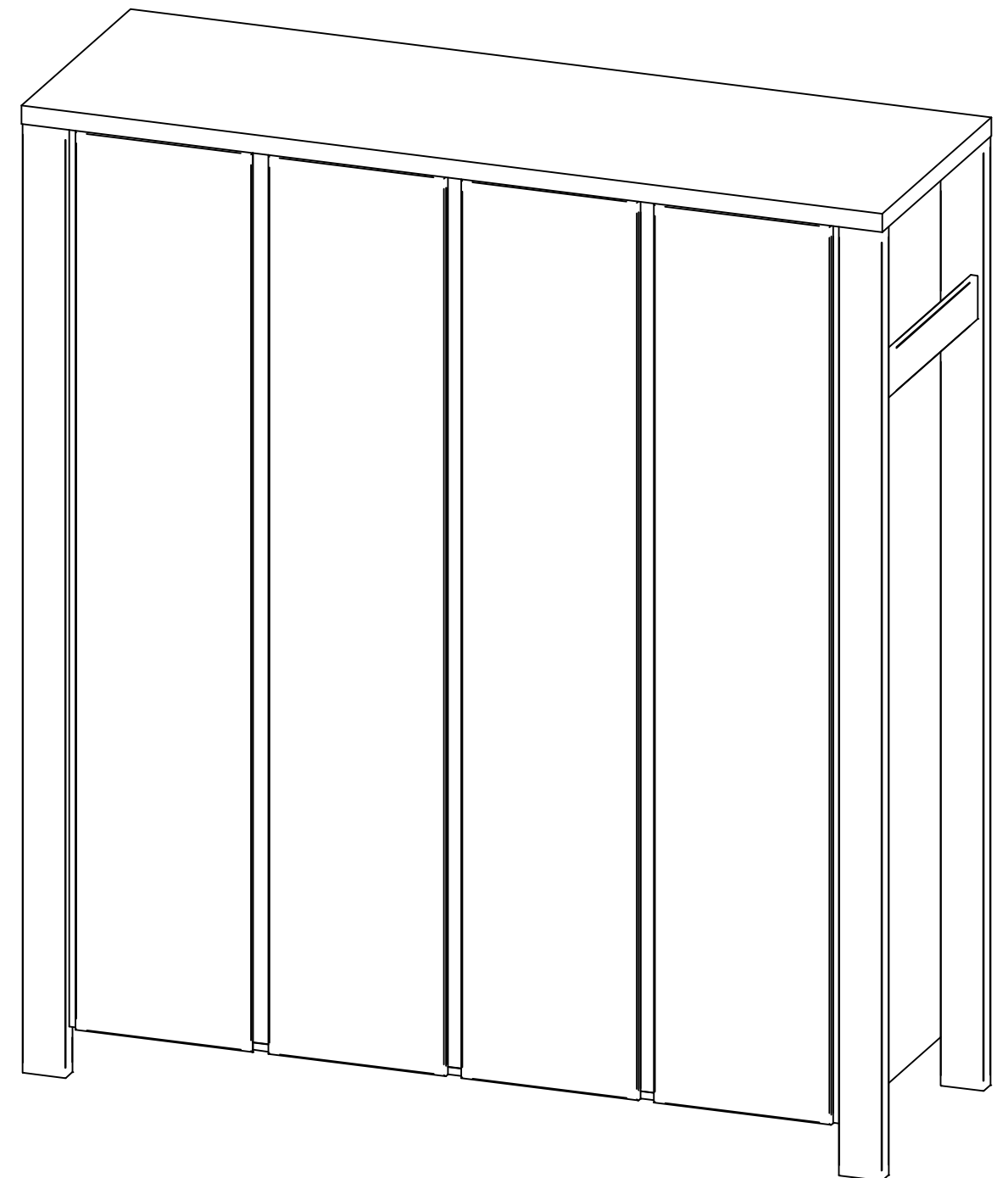
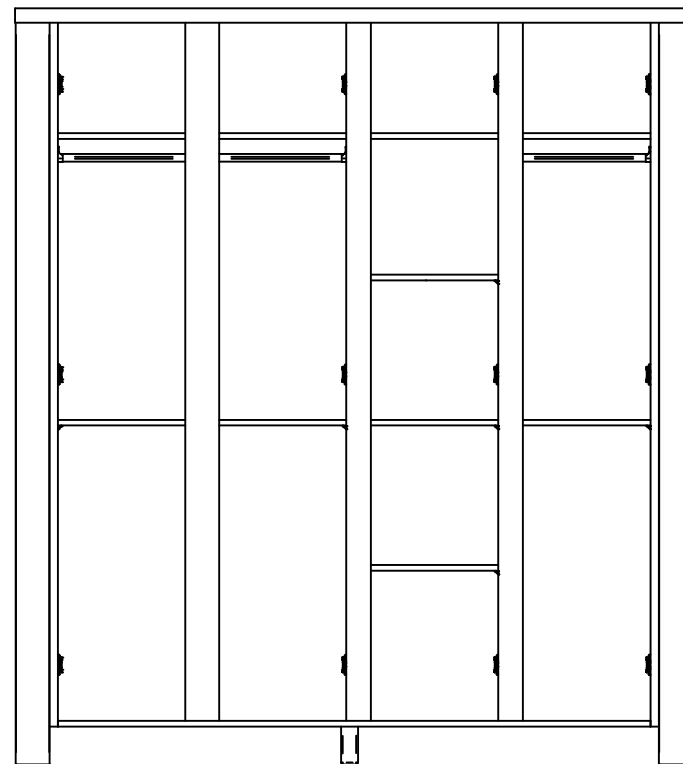

Inhalt - Contents - Contenu - Inhoud - contenuto -contenido-conteúdo - περιεχόμενο

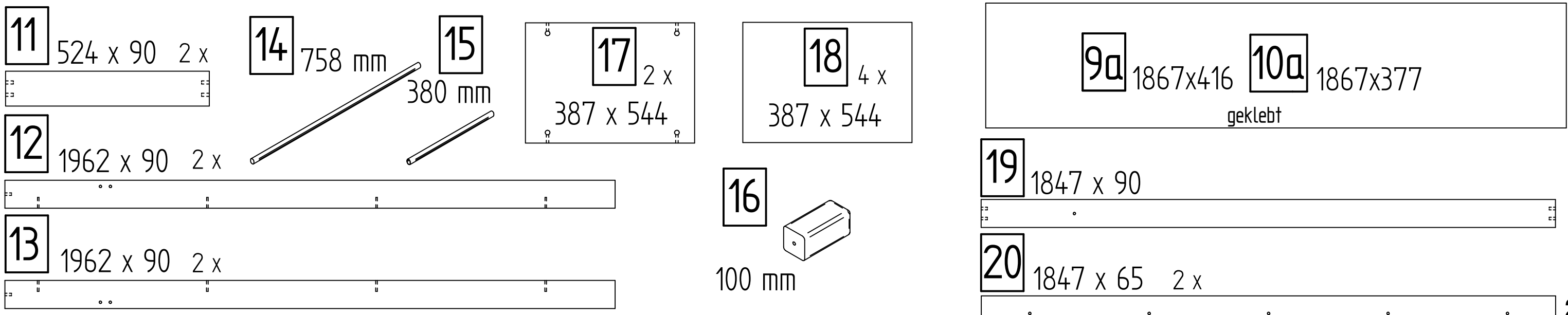
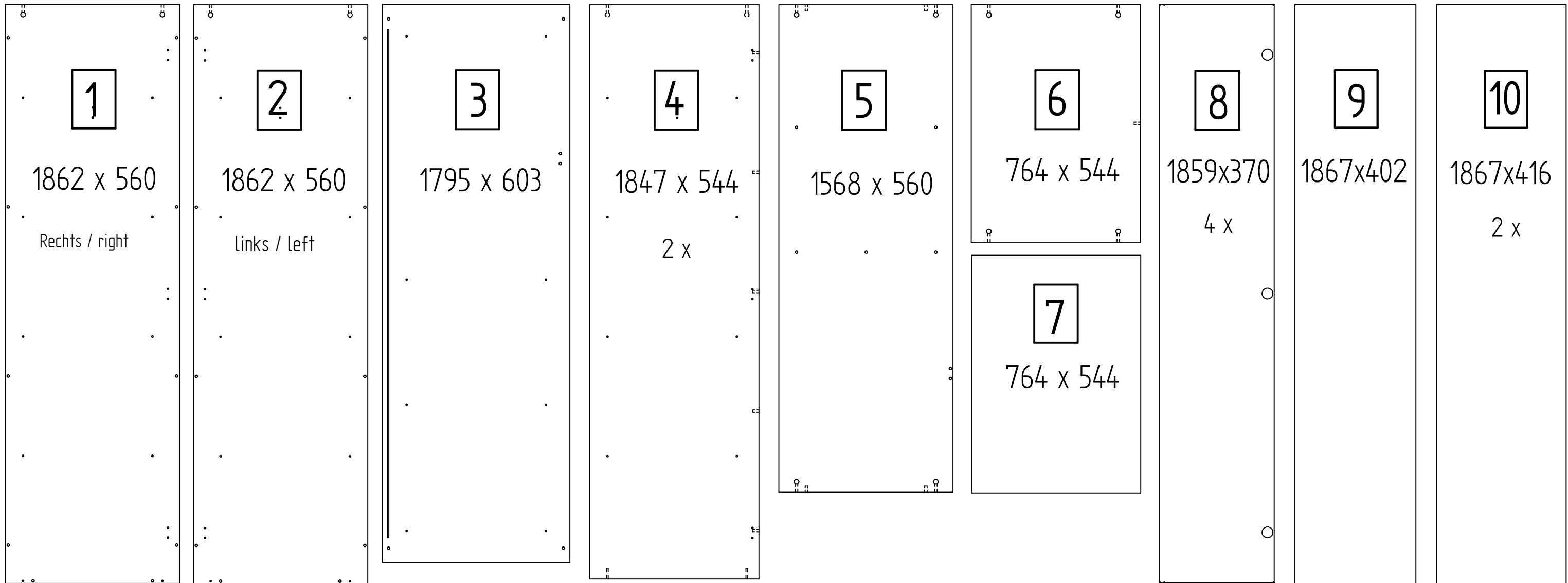

Vormontage:

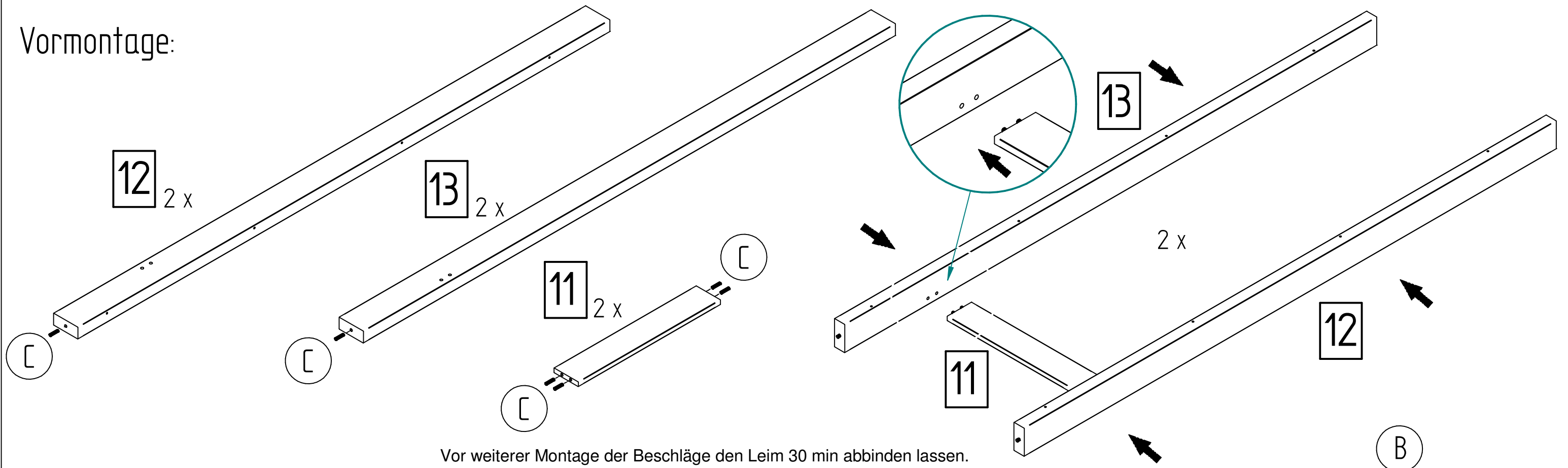

Vor weiterer Montage der Beschläge den Leim 30 min abbinden lassen.
 Before further installation of the fittings the glue thicken for 30 minutes.
 Avant l'installation ultérieure des raccords, la colle épaissir pendant 30 minutes.
 Voor verdere montage van het beslag de lijm dik gedurende 30 minuten.
 Prima ulteriore installazione dei raccordi addensare la colla per 30 minuti.
 Antes de la instalación posterior de los accesorios de la cola espesar durante 30 minutos.
 Antes da instalação posterior dos acessórios a engrossar cola durante 30 minutos.
 Πριν από την περαιτέρω εγκατάσταση των εξαρτημάτων πικνώσει η κόλλα για 30 λεπτά.

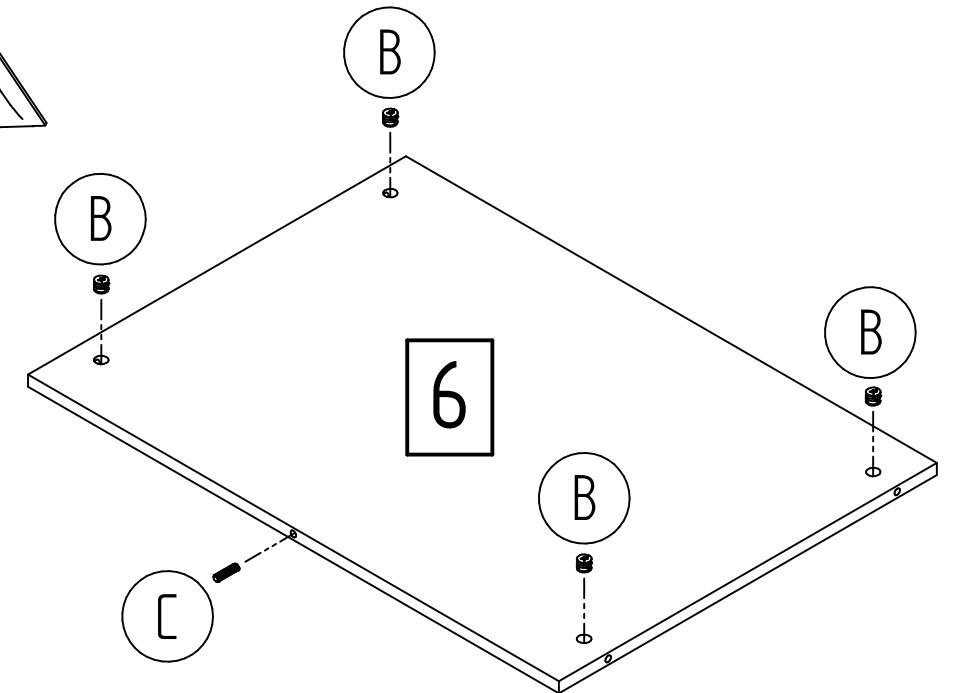
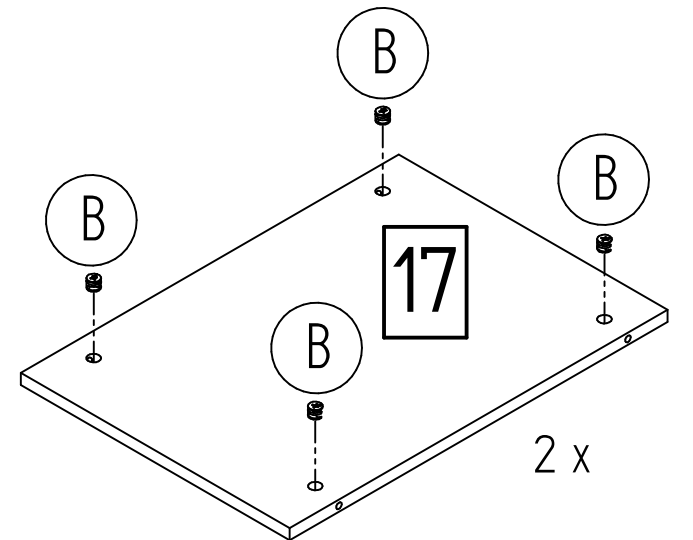
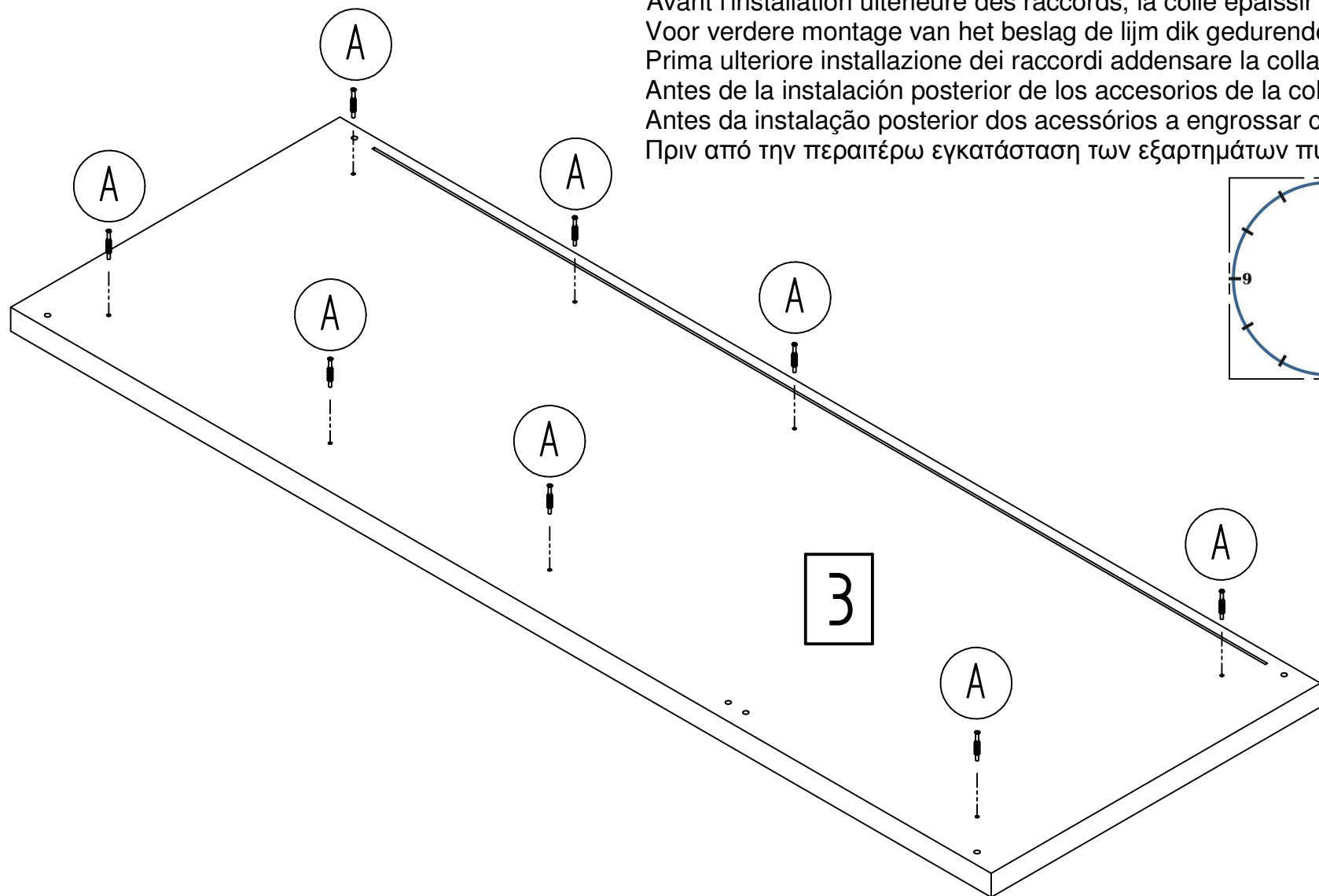
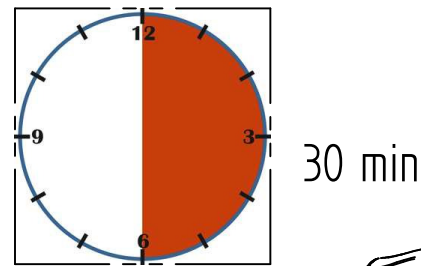

Vormontage:

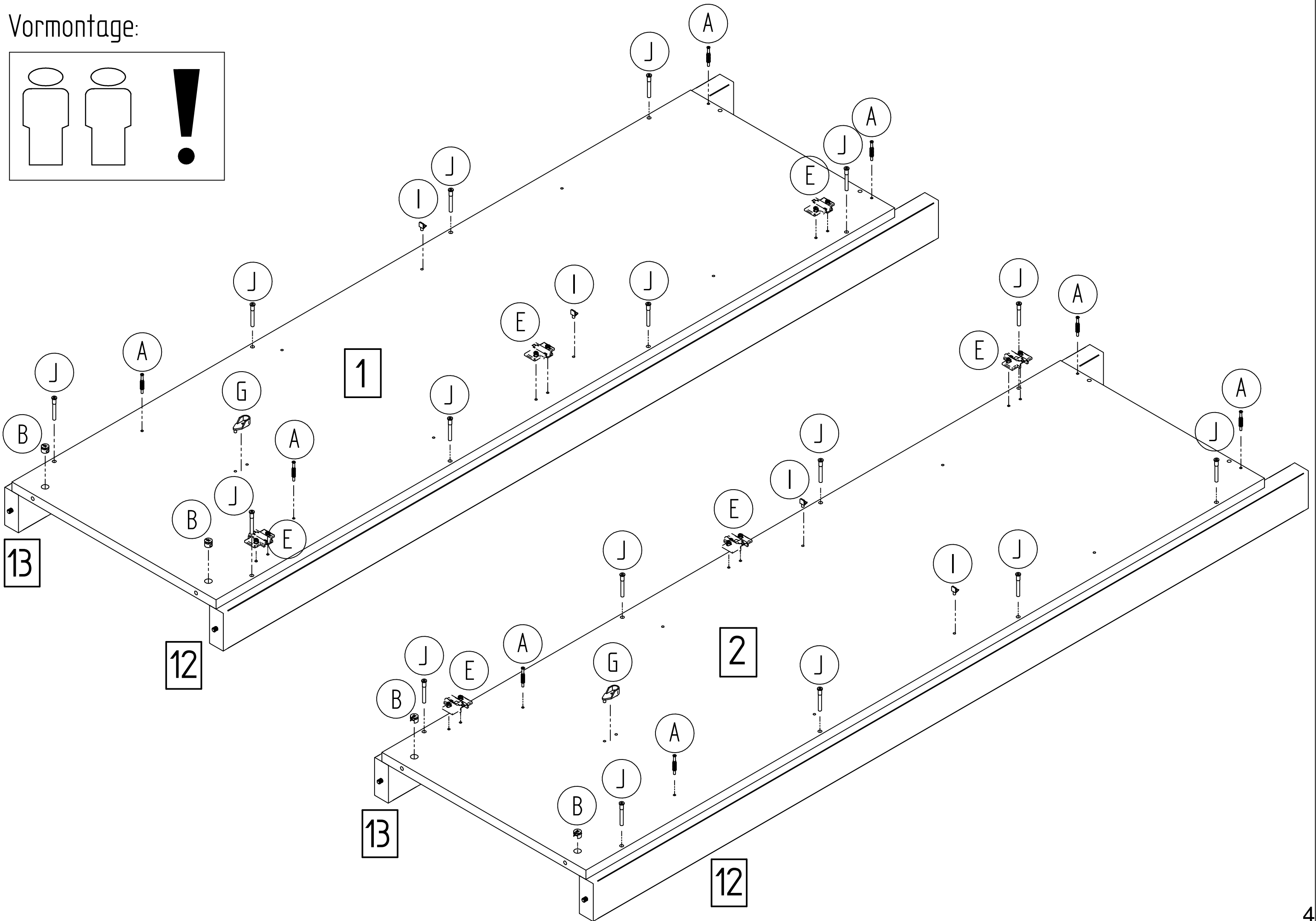
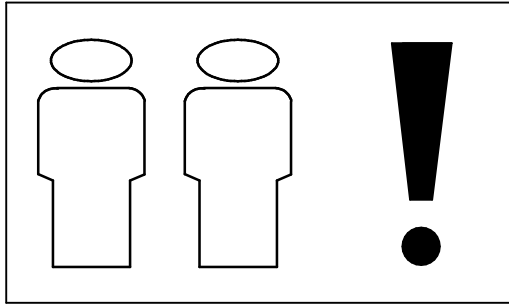

Vormontage:

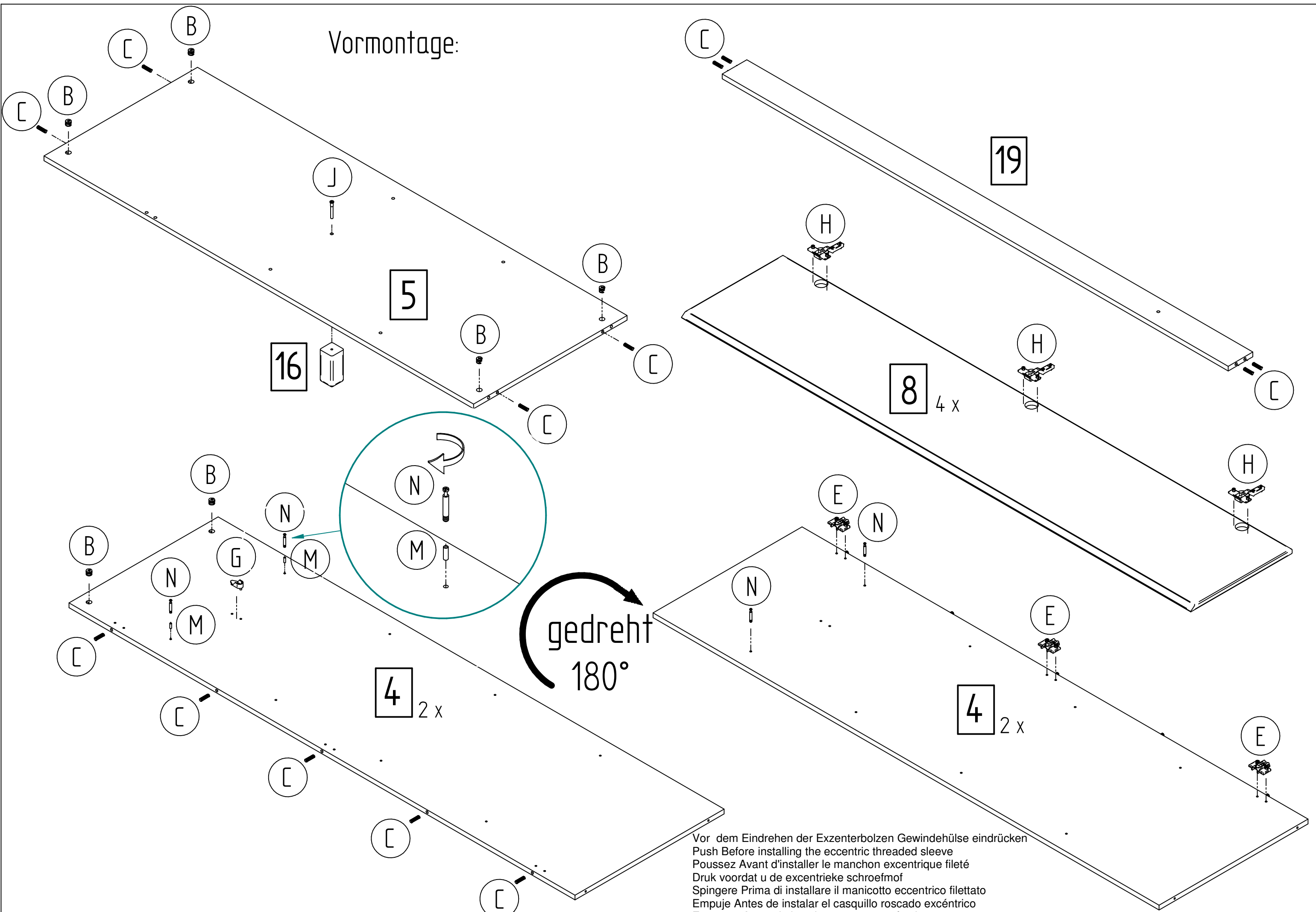

Vor dem Eindrehen der Exzenterbolzen Gewindehülse eindrücken
 Push Before installing the eccentric threaded sleeve
 Poussez Avant d'installer le manchon excentrique fileté
 Druk voordat u de excentrieke schroefmof
 Spingere Prima di installare il manicotto eccentrico filettato
 Empuje Antes de instalar el casquillo roscado excéntrico
 Empurrar Antes de instalar a manga excêntrica com rosca
 Πριν από την εγκατάσταση Σπρώξτε τον εκκεντρικό σπείρωμα μανίκι

Zusammenbau:

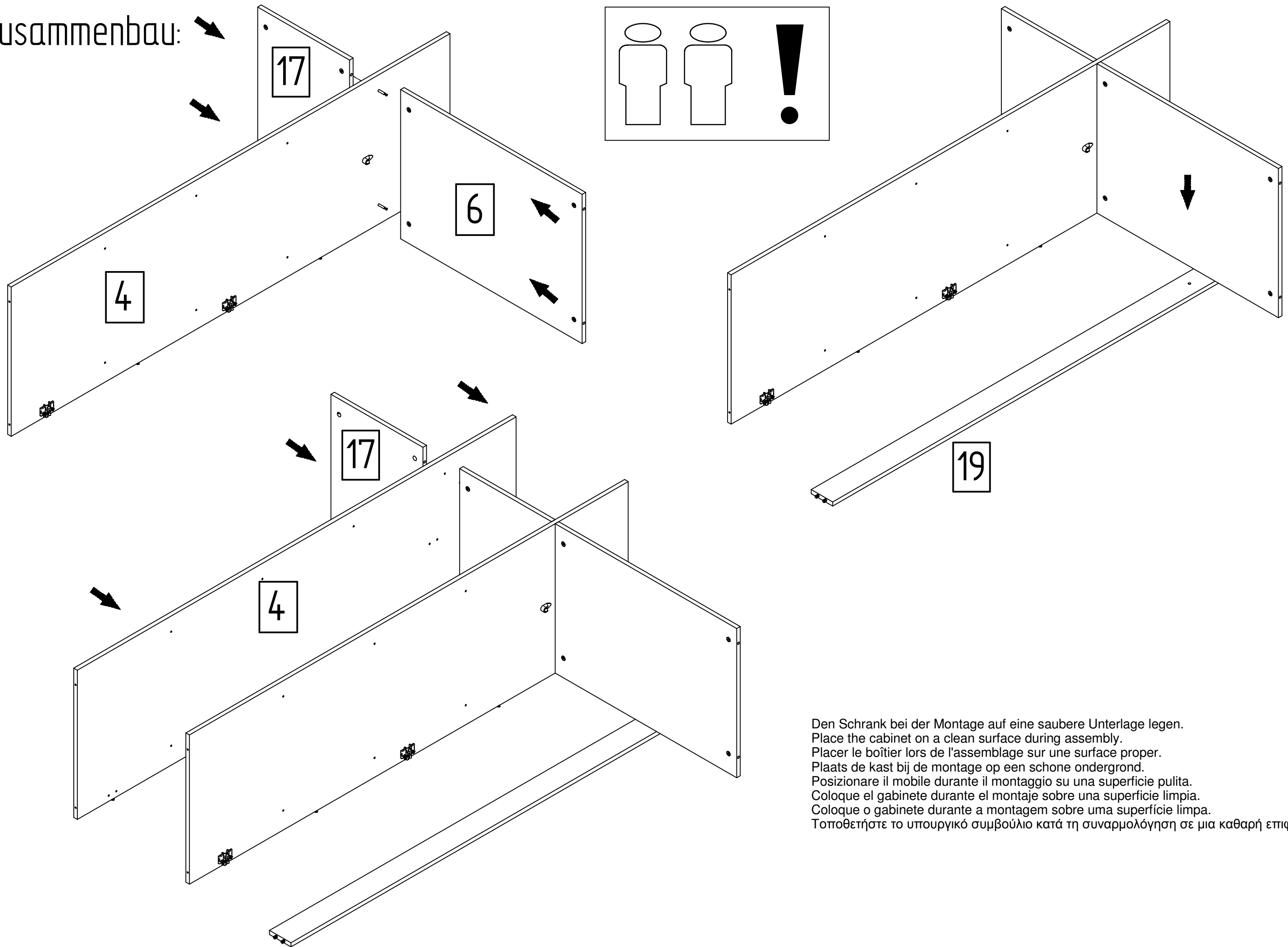

Den Schrank bei der Montage auf eine saubere Unterlage legen.
Place the cabinet on a clean surface during assembly.
Placer le boîtier lors de l'assemblage sur une surface propre.
Plaats de kast bij de montage op een schone ondergrond.
Posizionare il mobile durante il montaggio su una superficie pulita.
Coloque el gabinete durante el montaje sobre una superficie limpia.
Coloque o gabinete durante a montagem sobre uma superfície limpa.
Τοποθετήστε το υπουργικό συμβούλιο κατά τη συναρμολόγηση σε μια καθαρή επιφάνεια.

Zusammenbau:

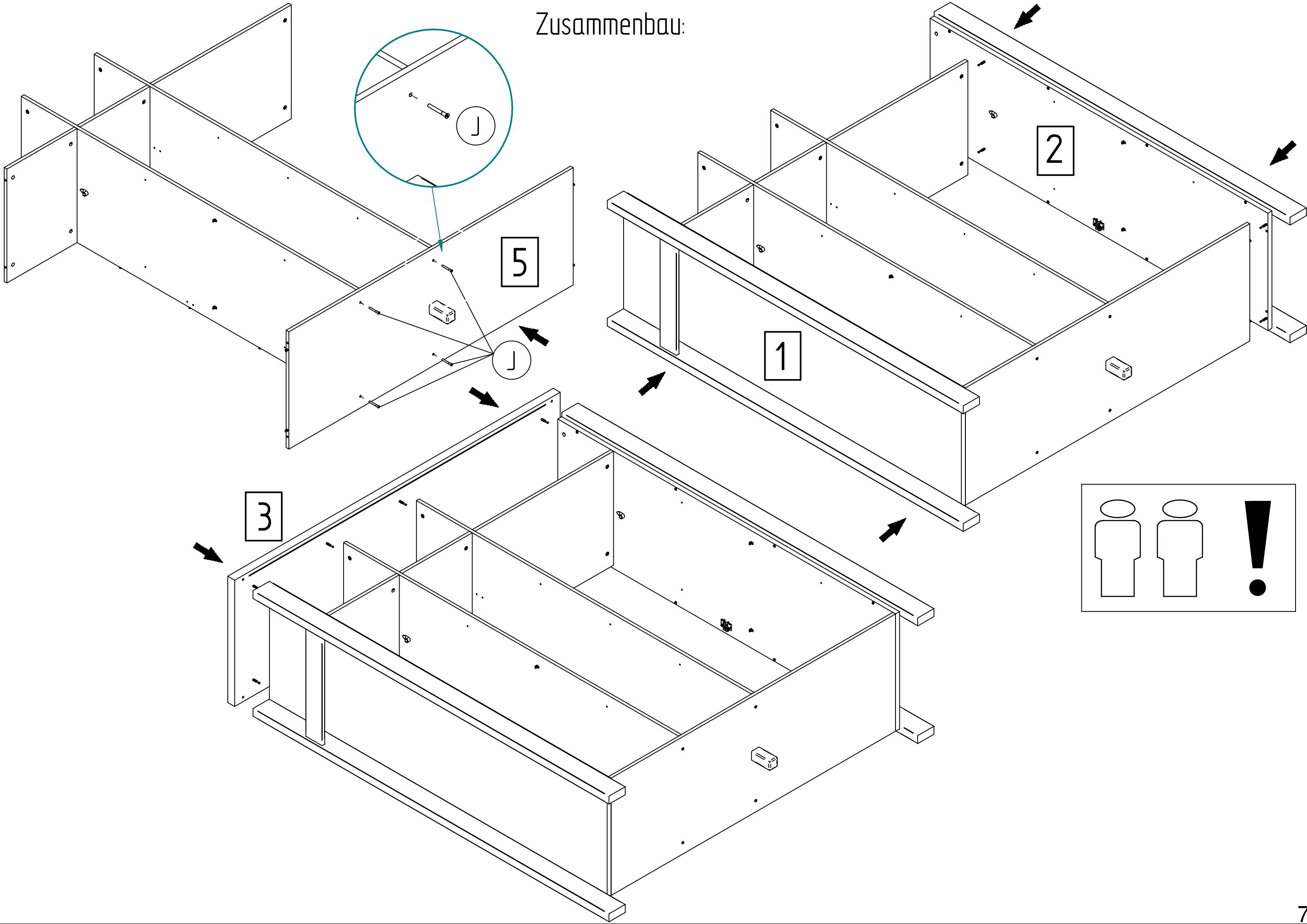

Zusammenbau:

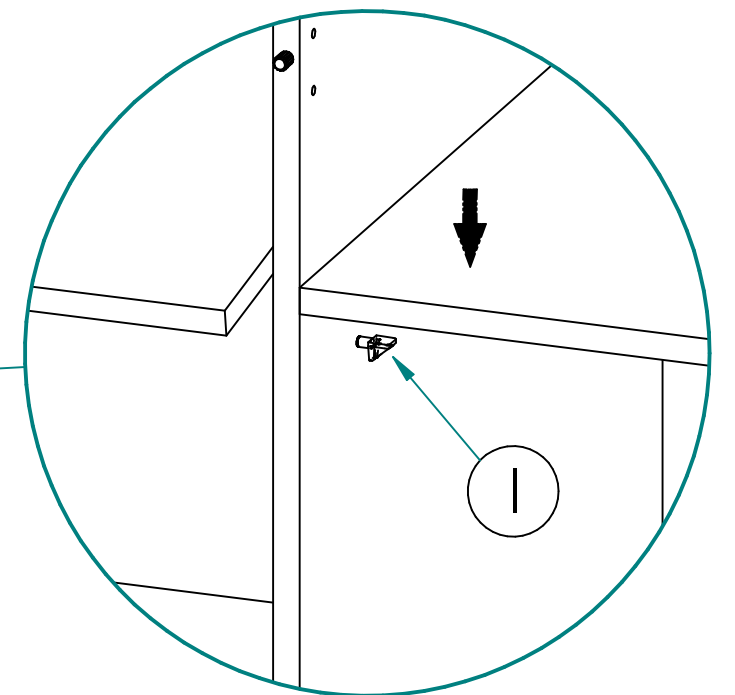
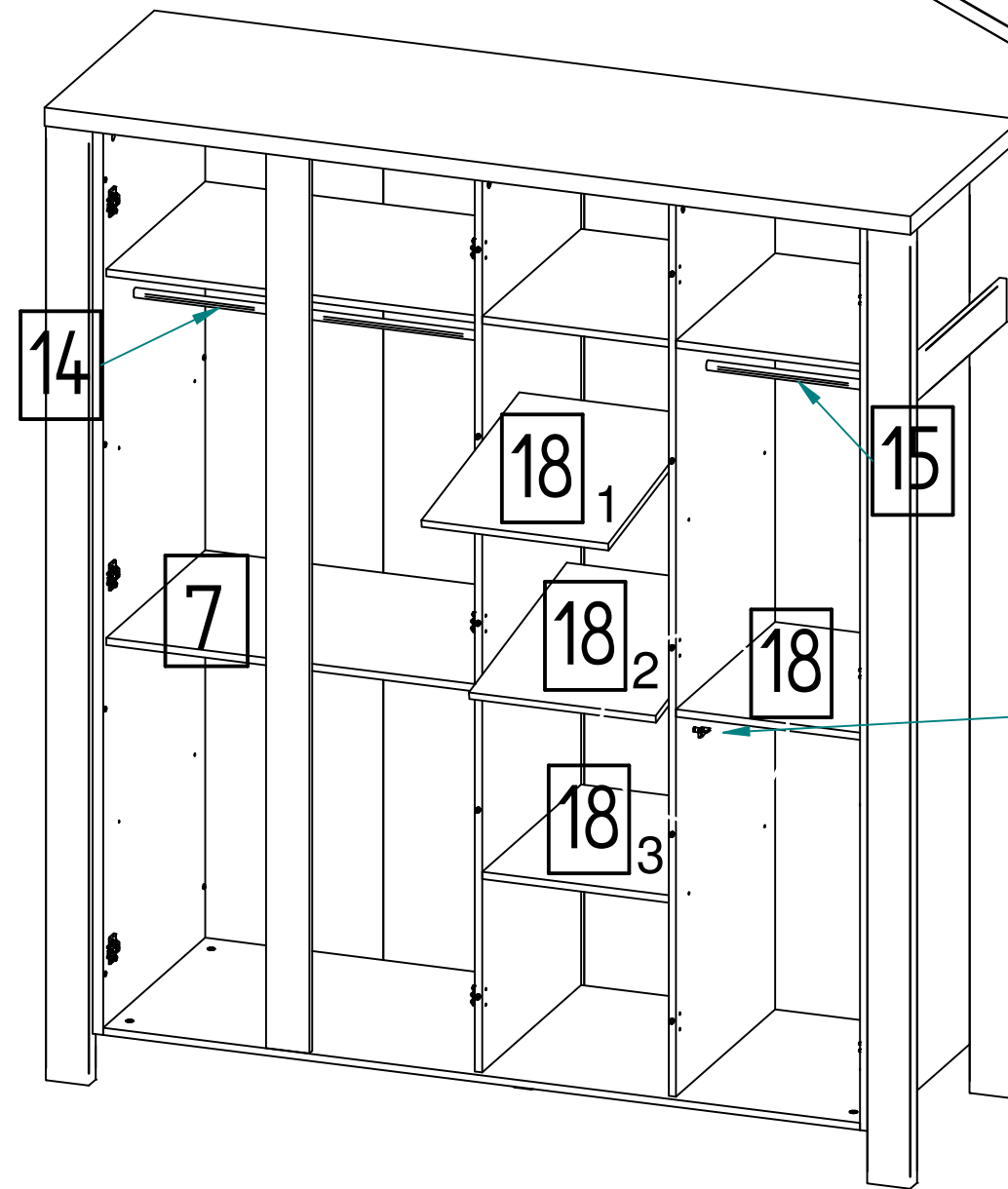
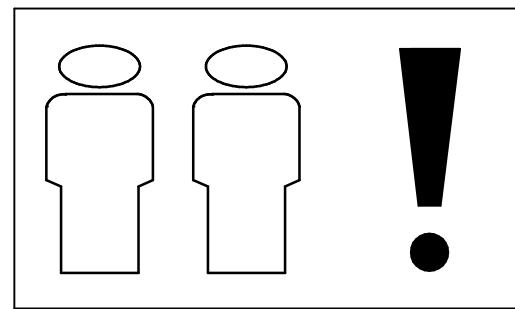
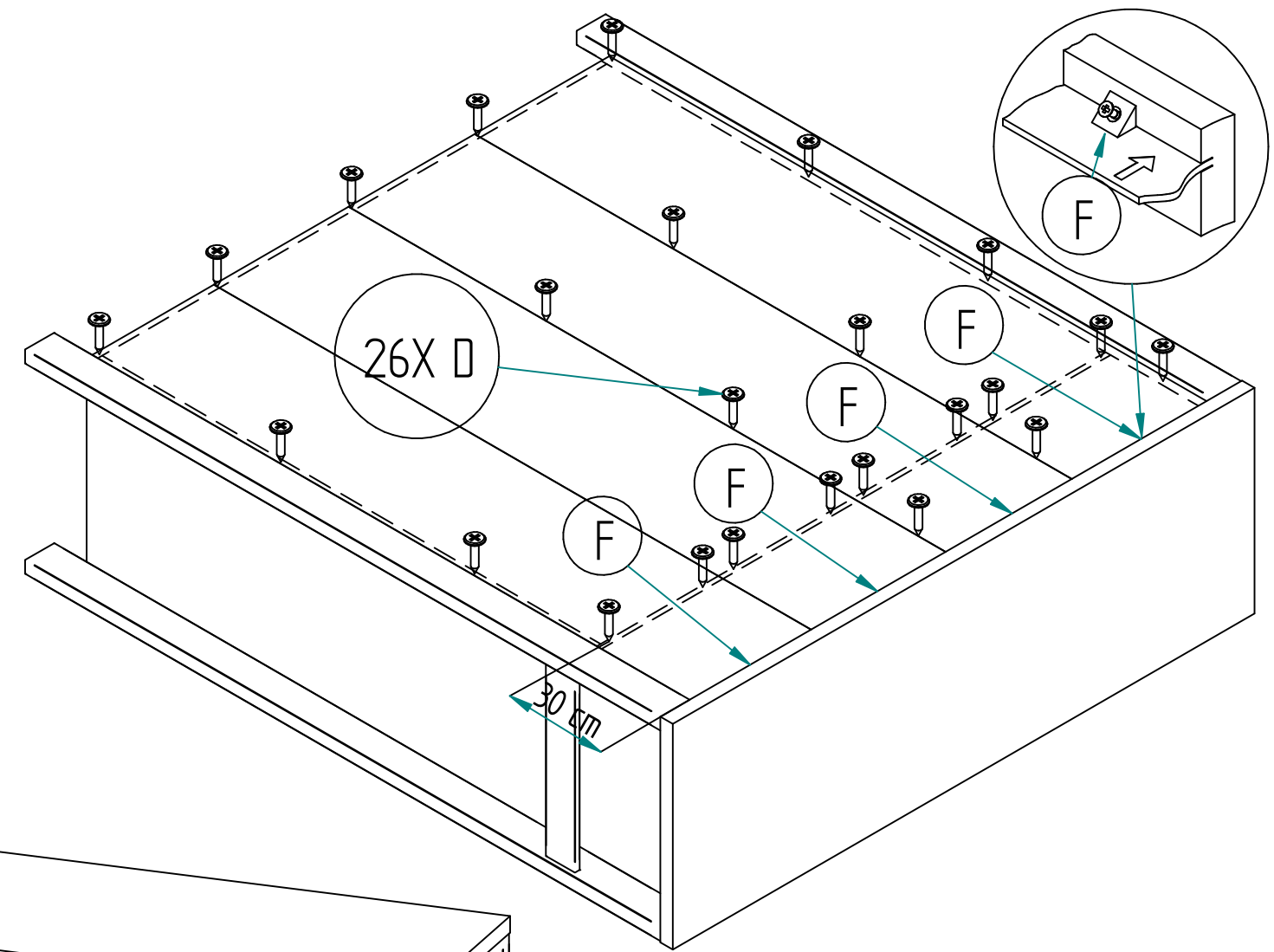
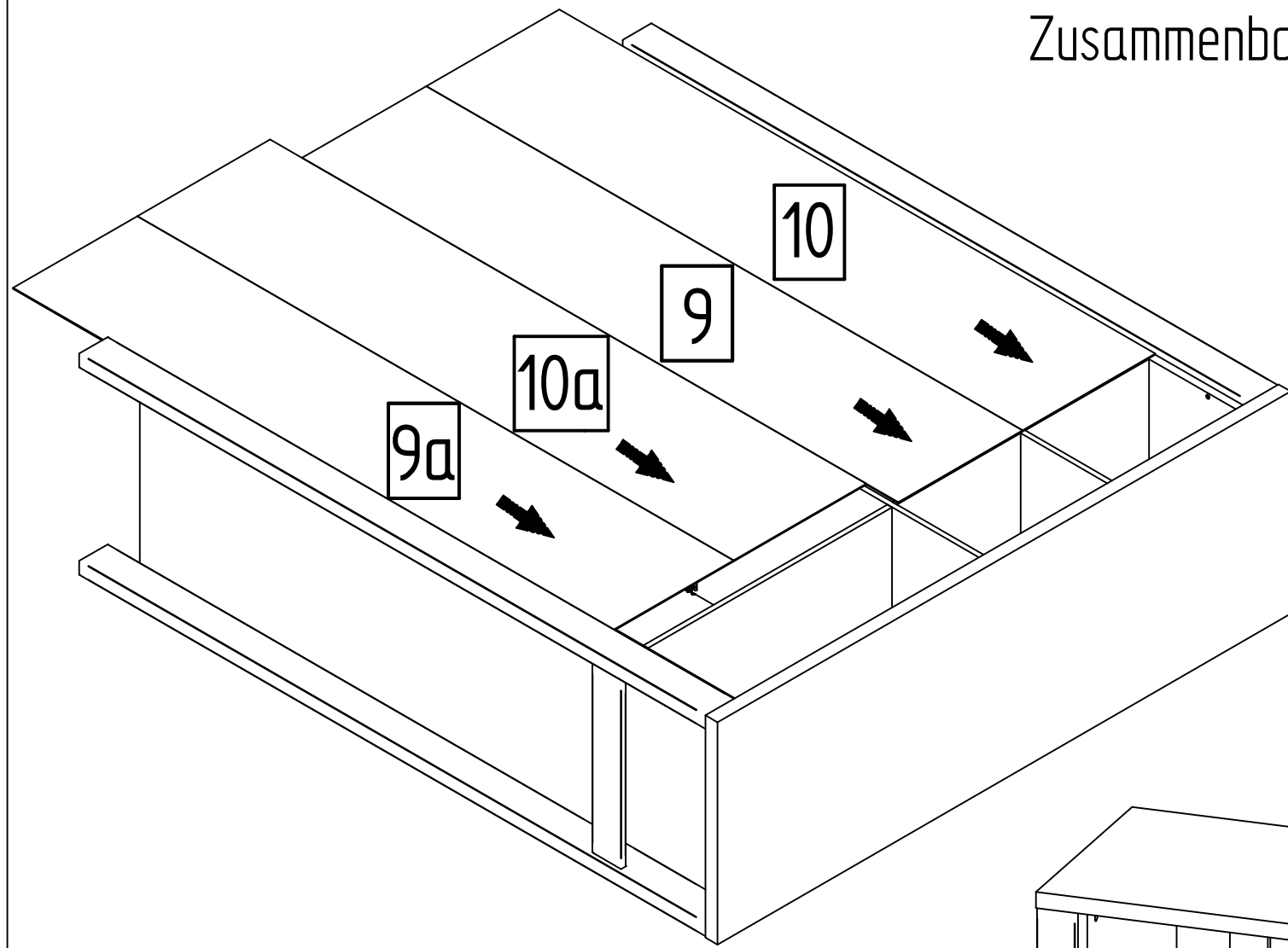

Zusammenbau:

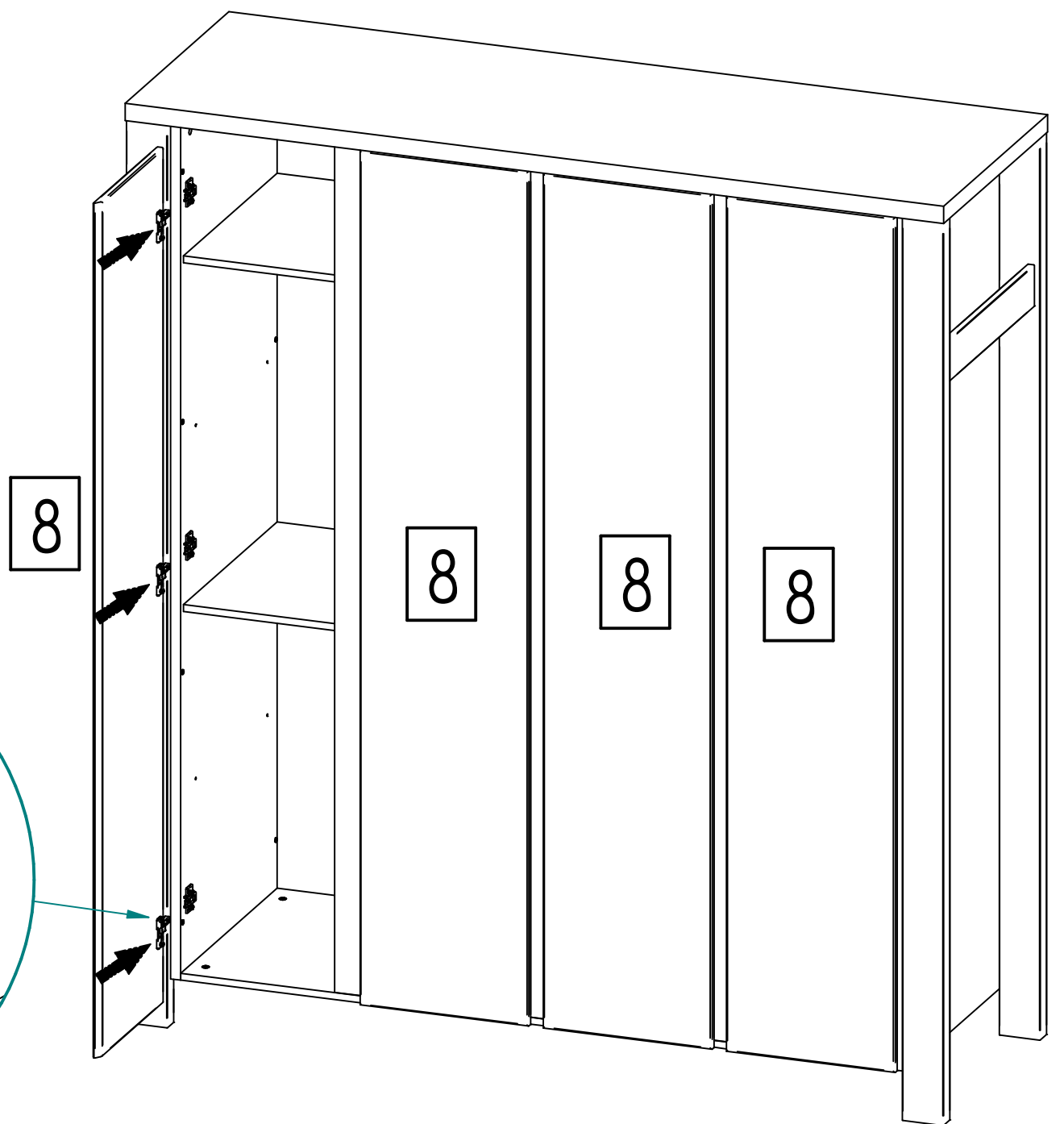
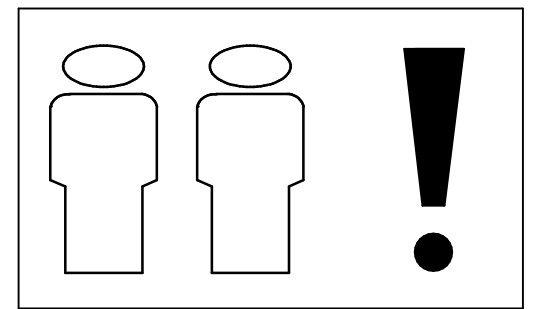
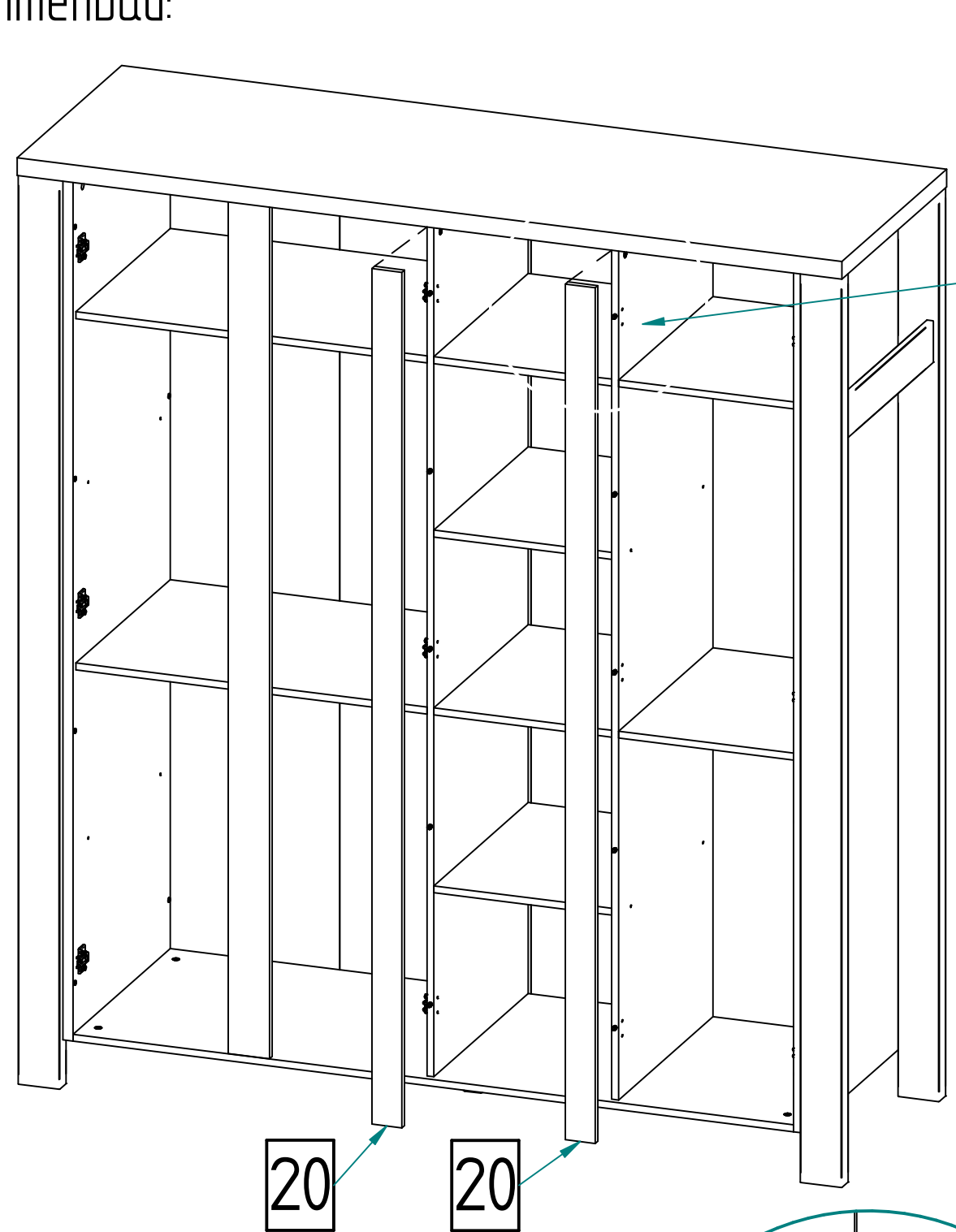

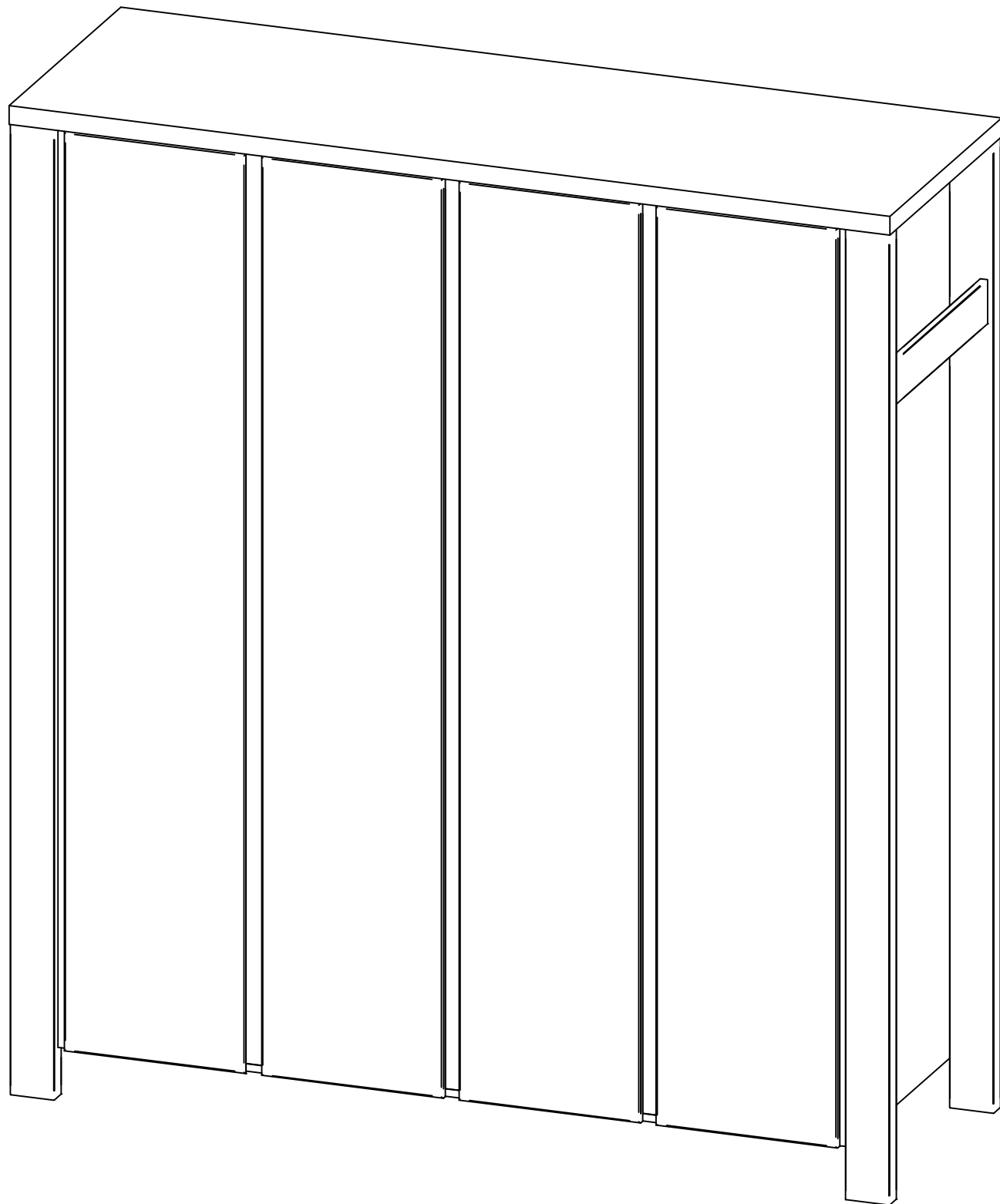

... weitere Infos über unsere Produkte unter

www.schardt.com

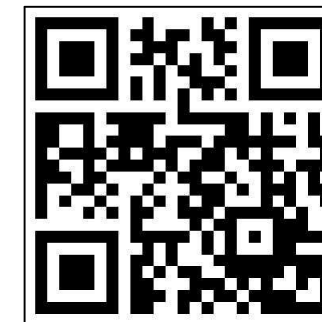

Schardt GmbH & Co. KG
Am Riegel 15
96268 Mitwitz
Tel. 09266/9907-0
Fax 09266/9907-77
E-Mail: info@schardt.com