

Inhalt - Contents - Contenu - Inhoud - contenuto - contenido - conteúdo - περιεχόμενο

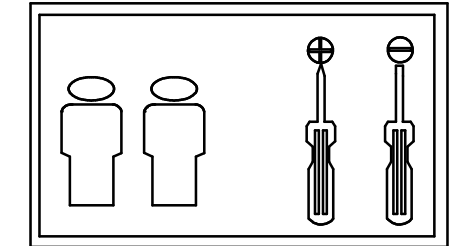





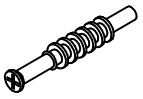

Wickelkommode changing unit Commode Kommode

# Milano 05 649 TYP 1

DIN EN 12221:2008+A1:2013

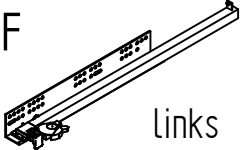
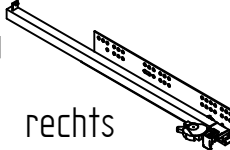

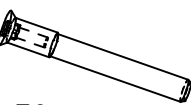
Beschlagbeutel:

A  10 x	B  15 ohne Rand 10 x	C  8 x 30 26 x
D  3 x 16 20 x	E  15 x	F  links 6 x
G  rechts 6 x	H  6,3 x 10 24 x	I  7 x 50 21 x
J  3 x		

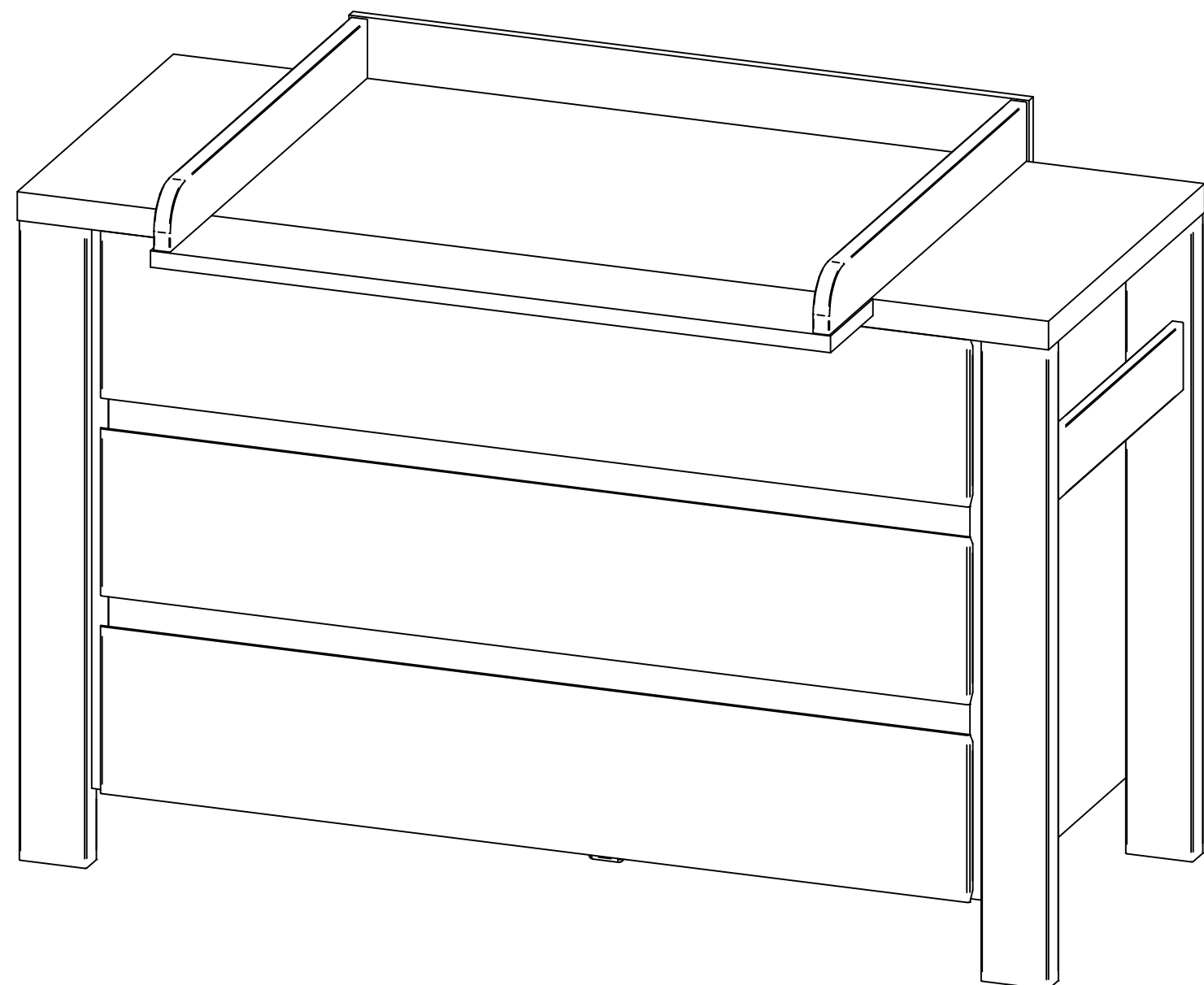

Inhalt - Contents - Contenu - Inhoud - contenuto -contenido-conteúdo - περιεχόμενο

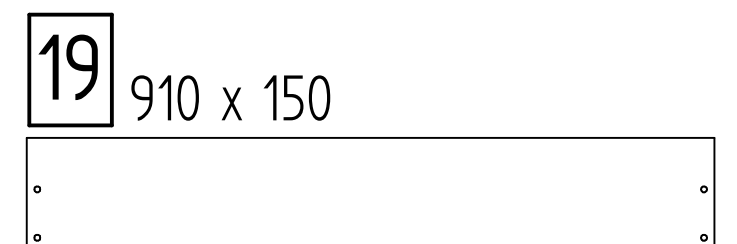
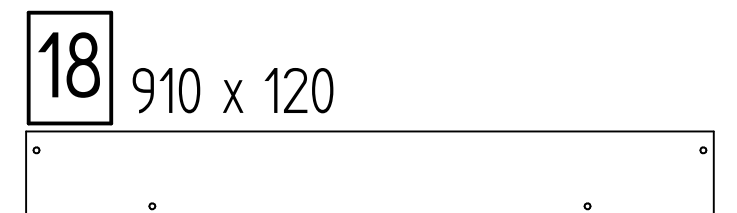
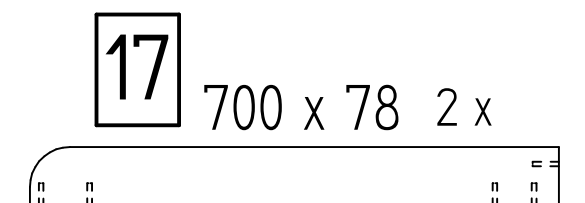
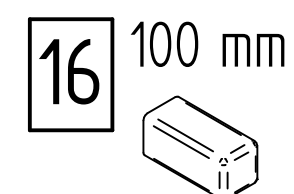
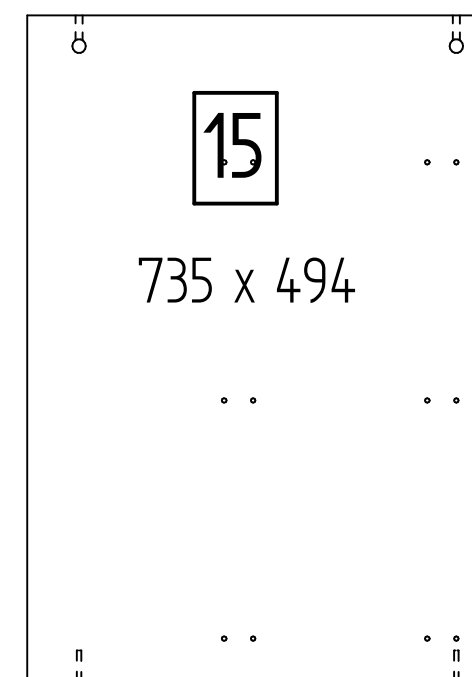
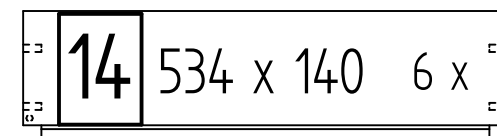
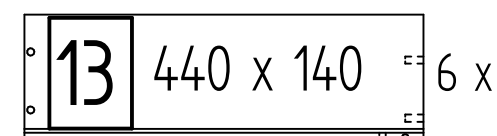
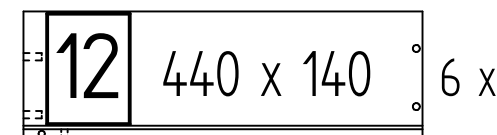
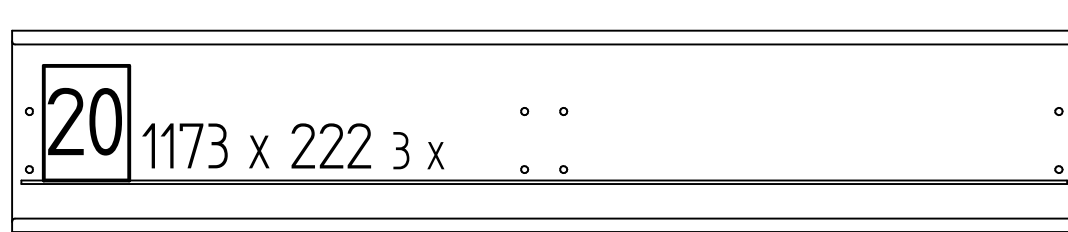
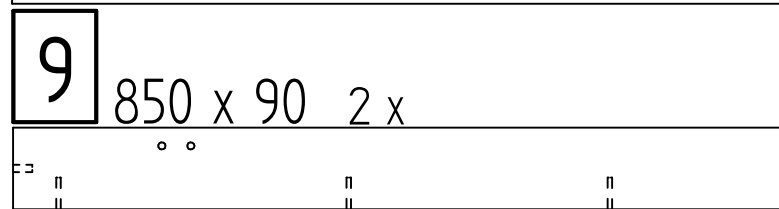
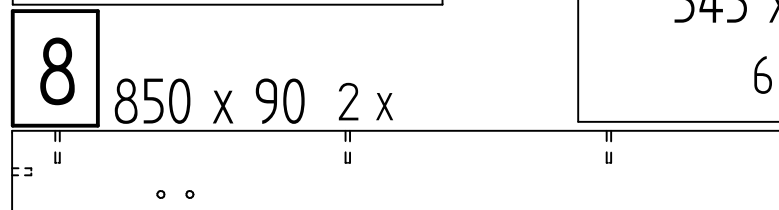
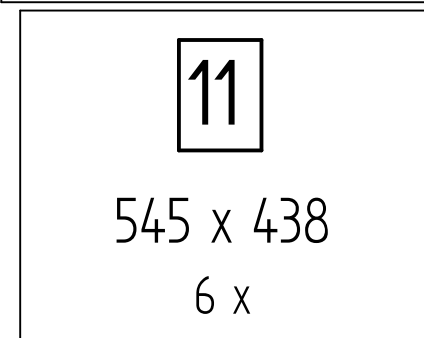
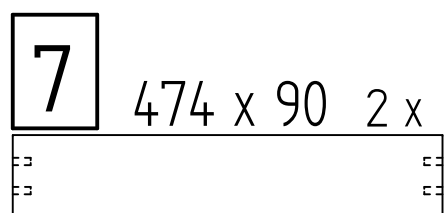
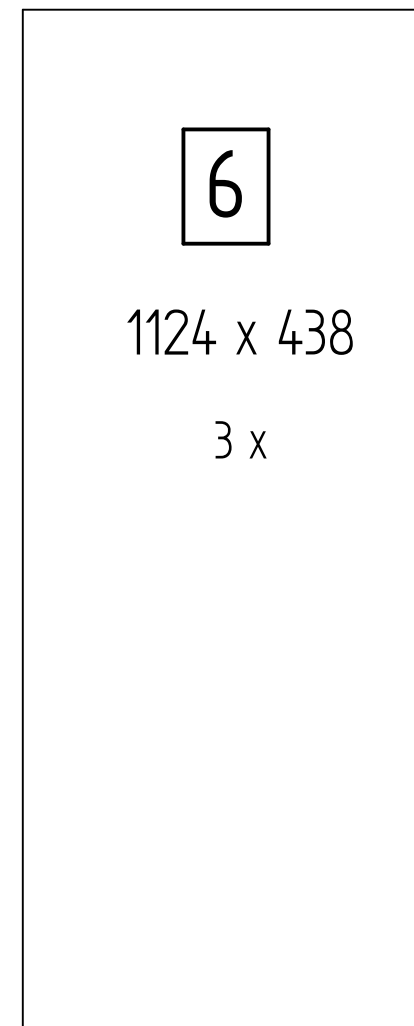
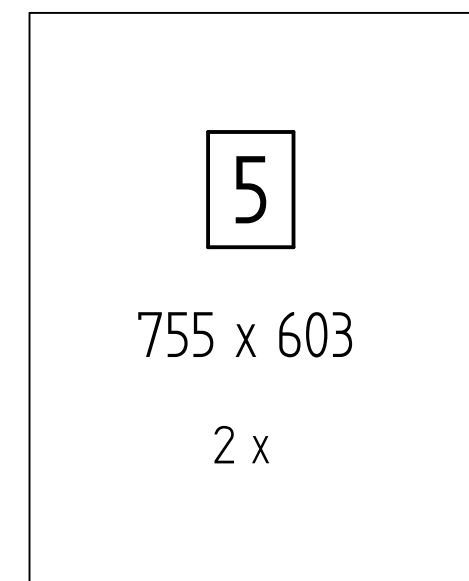
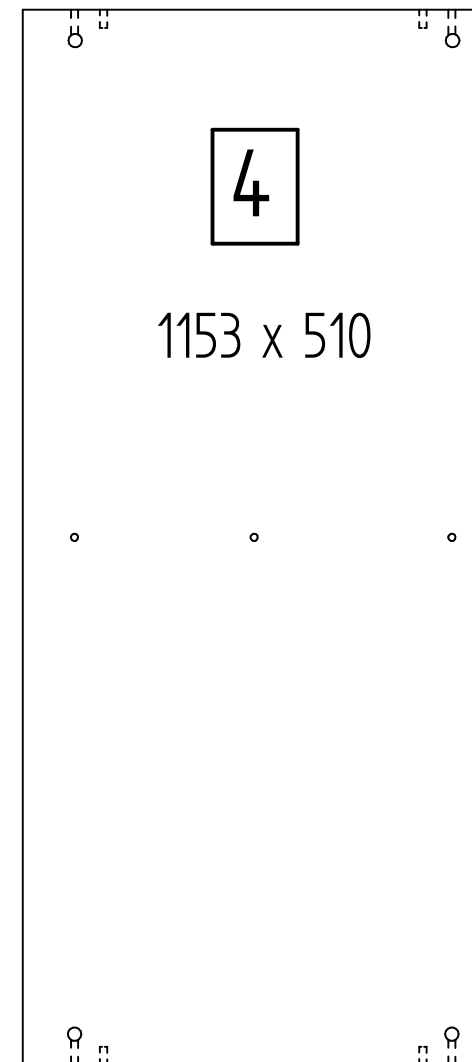
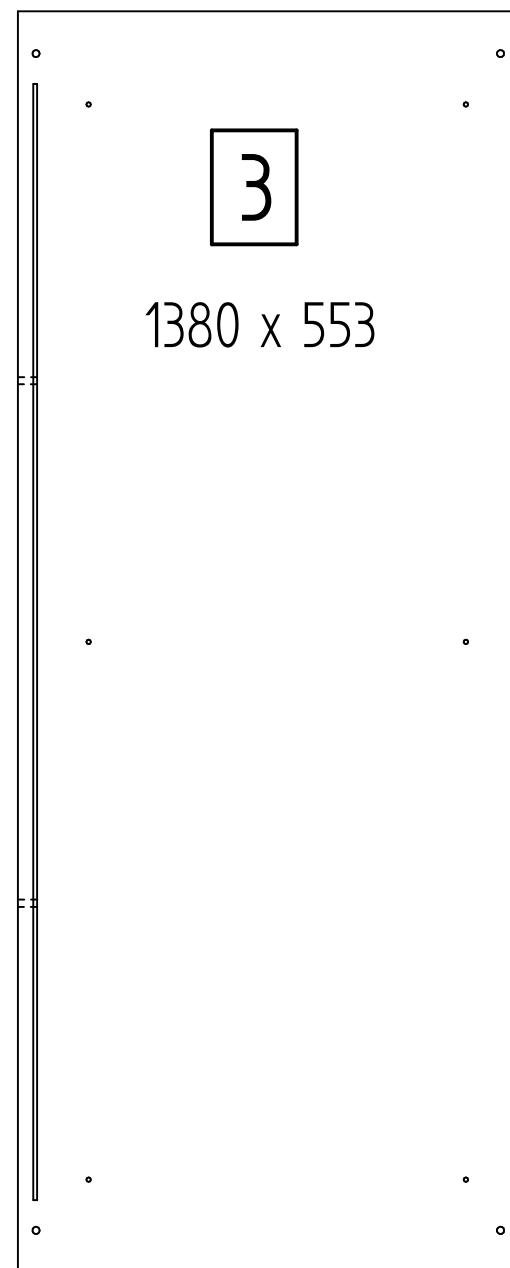
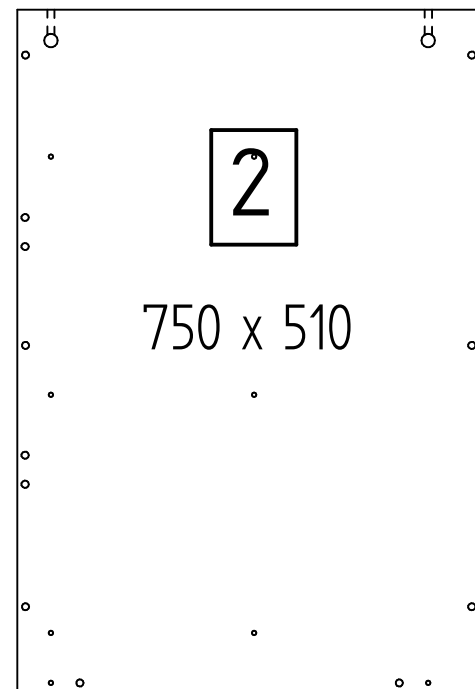
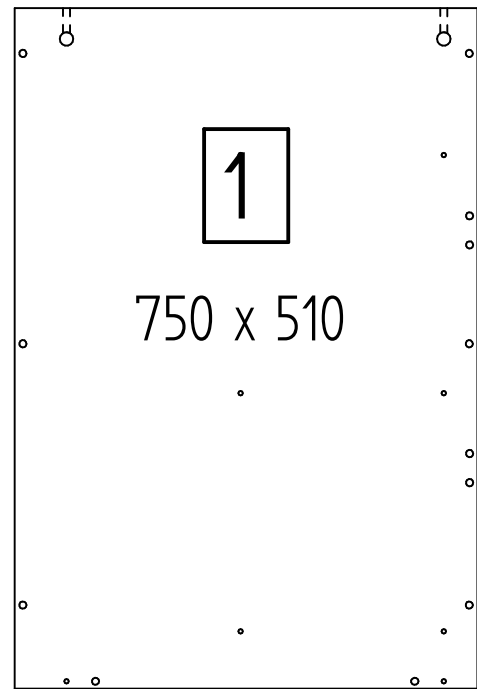

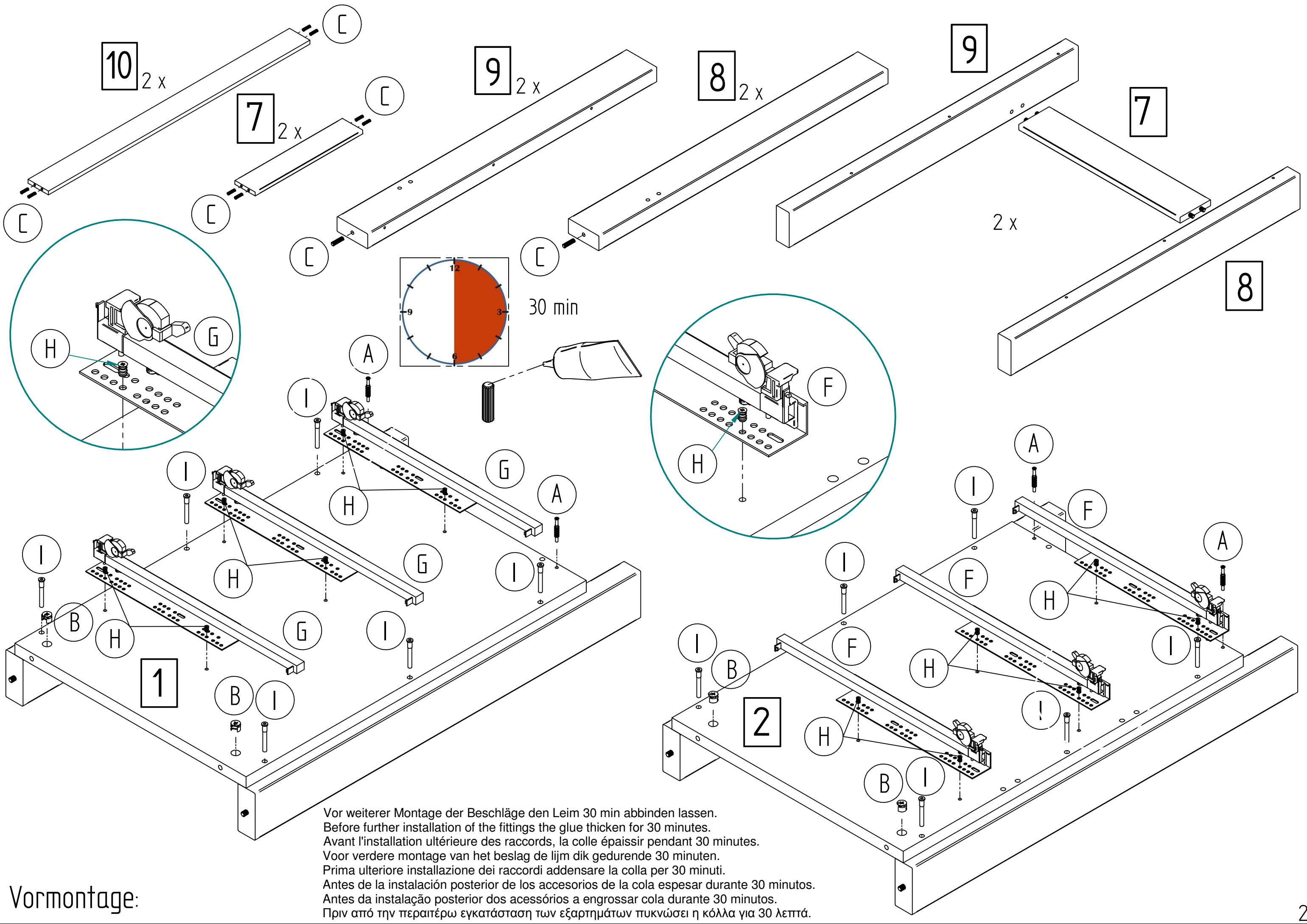

Vormontage:

Vor weiterer Montage der Beschläge den Leim 30 min abbinden lassen.  
 Before further installation of the fittings the glue thicken for 30 minutes.  
 Avant l'installation ultérieure des raccords, la colle épaissir pendant 30 minutes.  
 Voor verdere montage van het beslag de lijm dik gedurende 30 minuten.  
 Prima ulteriore installazione dei raccordi addensare la colla per 30 minuti.  
 Antes de la instalación posterior de los accesorios de la cola espesar durante 30 minutos.  
 Antes da instalação posterior dos acessórios a engrossar cola durante 30 minutos.  
 Πριν από την περαιτέρω εγκατάσταση των εξαρτημάτων πυκνώσει η κόλλα για 30 λεπτά.

# Vormontage:

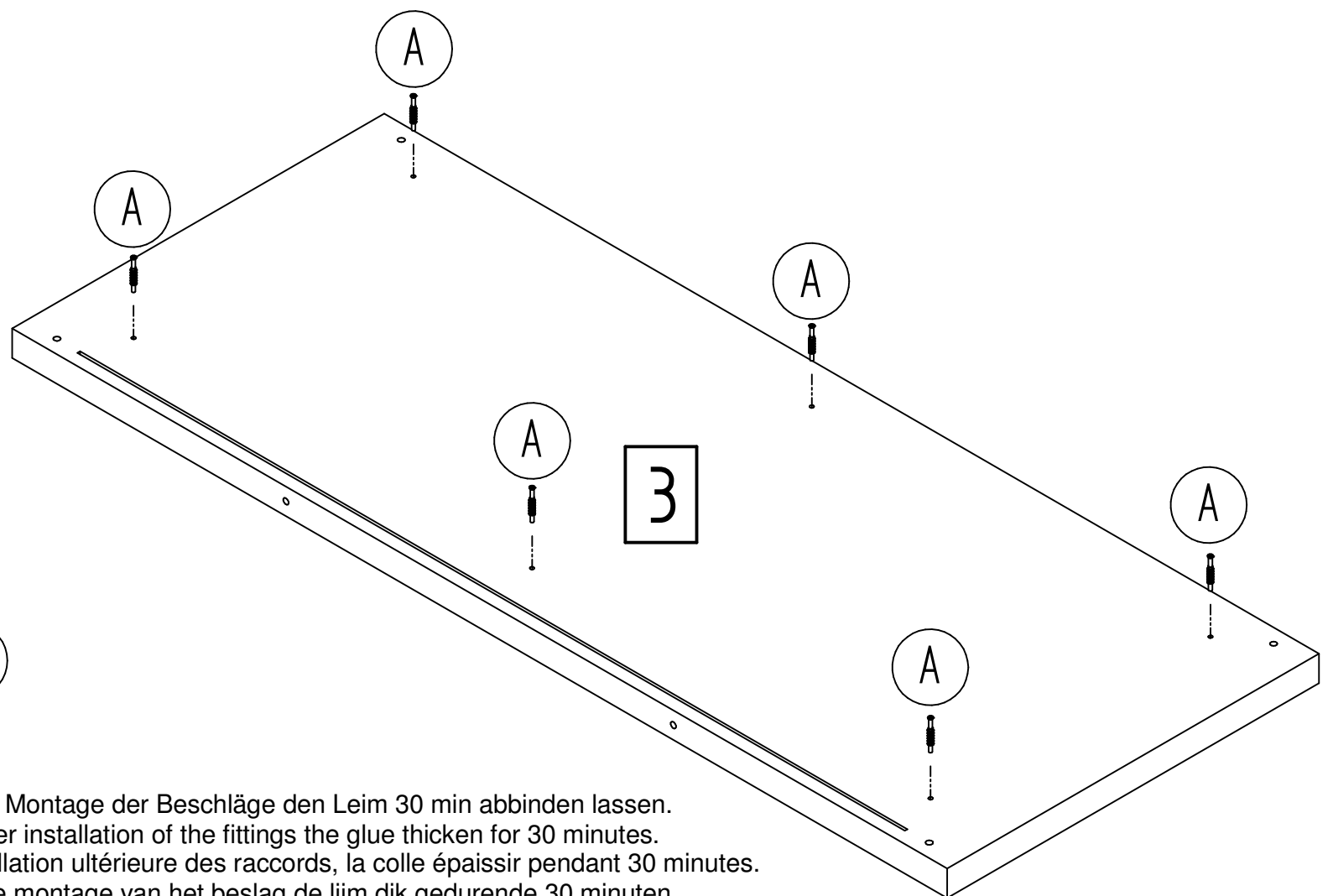
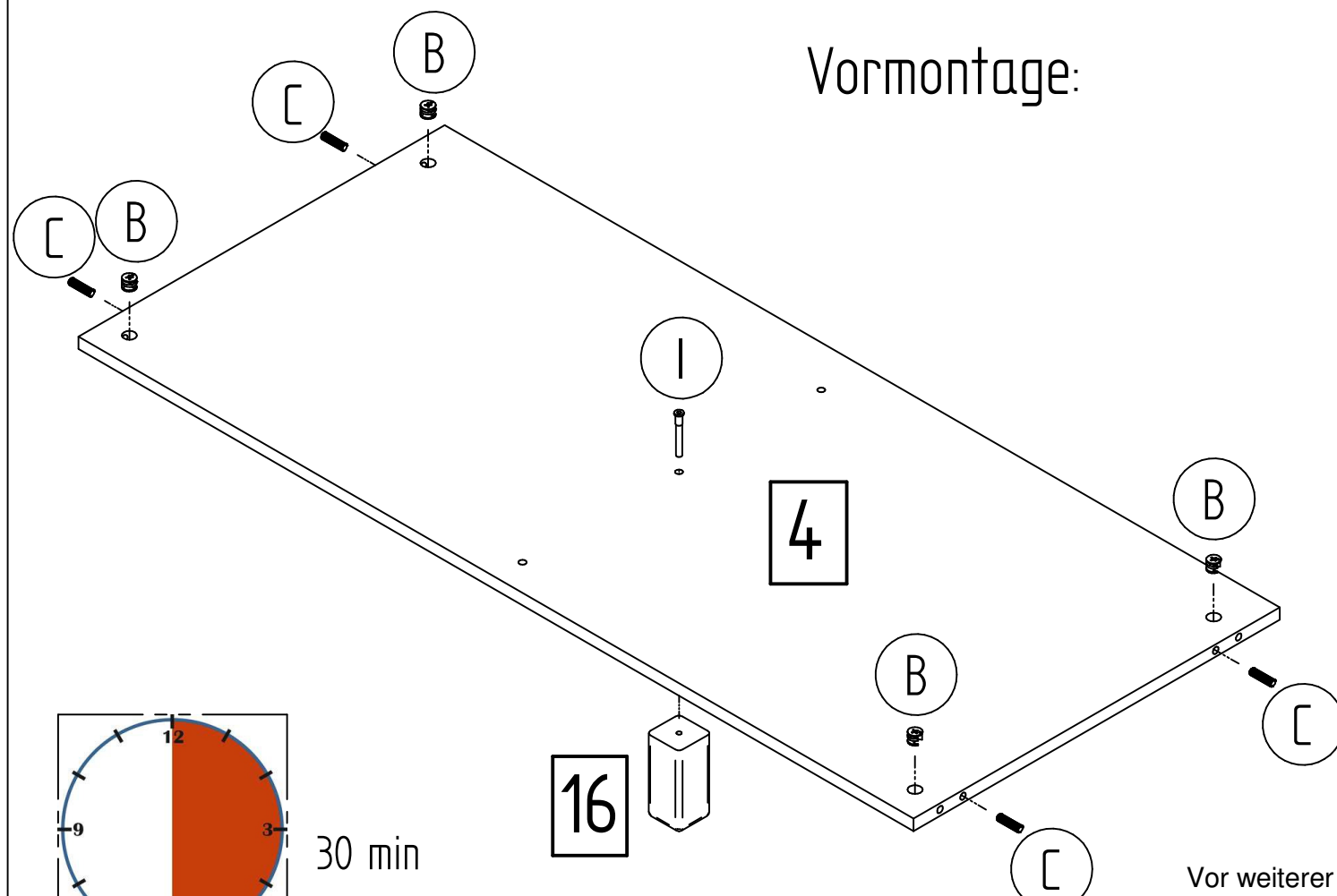

Vor weiterer Montage der Beschläge den Leim 30 min abbinden lassen.  
 Before further installation of the fittings the glue thicken for 30 minutes.  
 Avant l'installation ultérieure des raccords, la colle épaissir pendant 30 minutes.  
 Voor verdere montage van het beslag de lijm dik gedurende 30 minuten.  
 Prima ulteriore installazione dei raccordi addensare la colla per 30 minuti.  
 Antes de la instalación posterior de los accesorios de la cola espesar durante 30 minutos.  
 Antes da instalação posterior dos acessórios a engrossar cola durante 30 minutos.  
 Πριν από την περαιτέρω εγκατάσταση των εξαρτημάτων πικνώσει η κόλλα για 30 λεπτά.

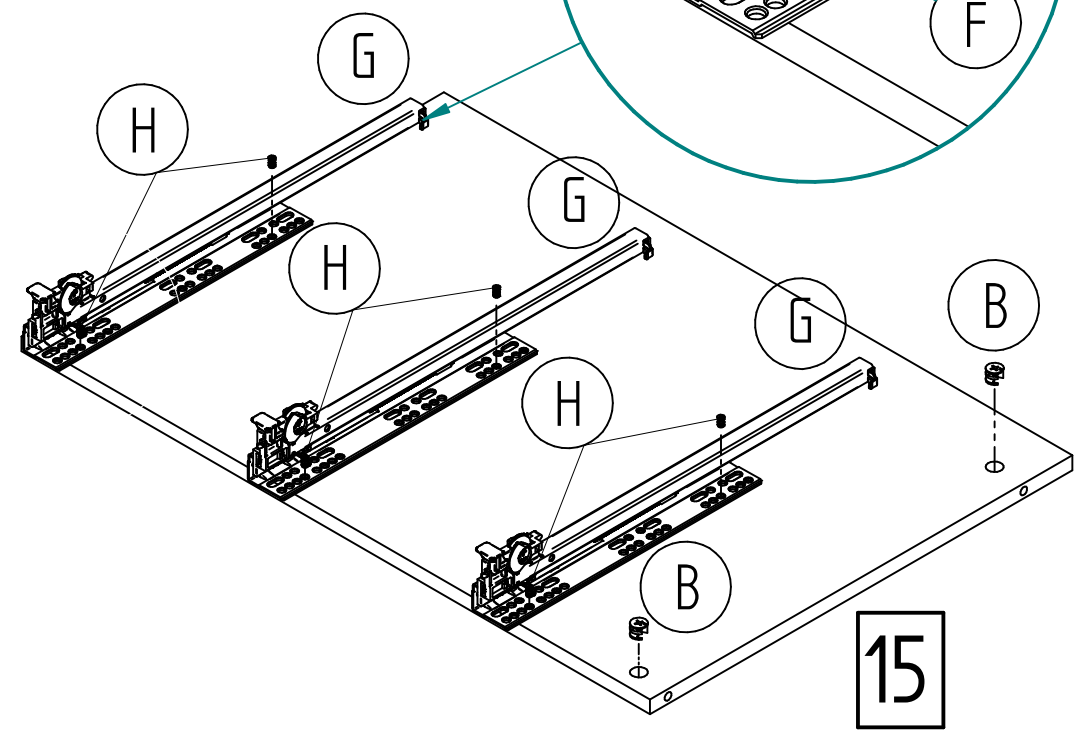
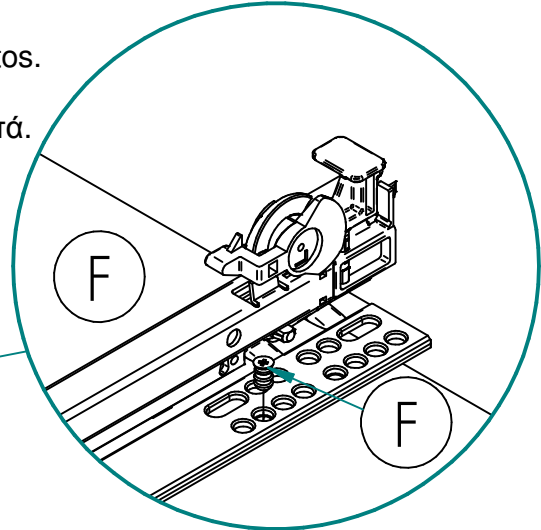
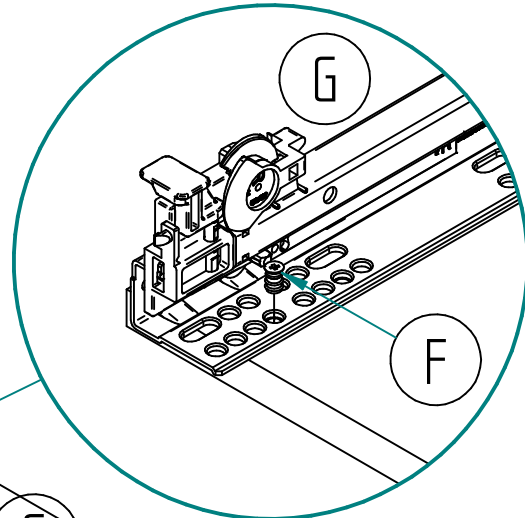

gedreht  
180°

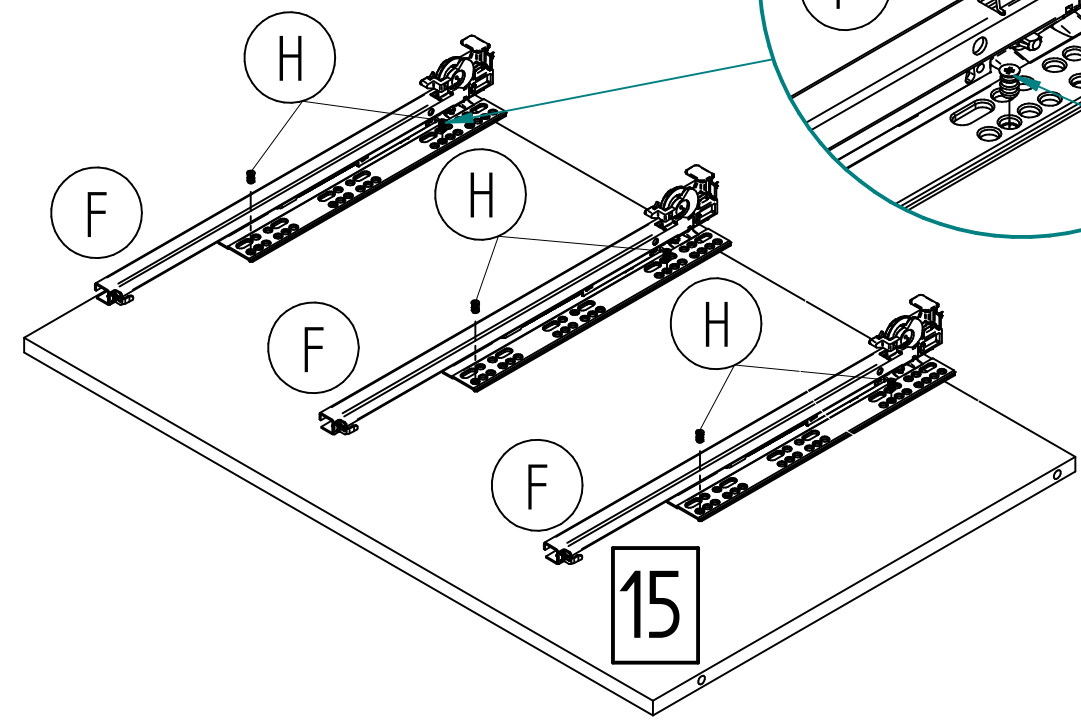

Vormontage:

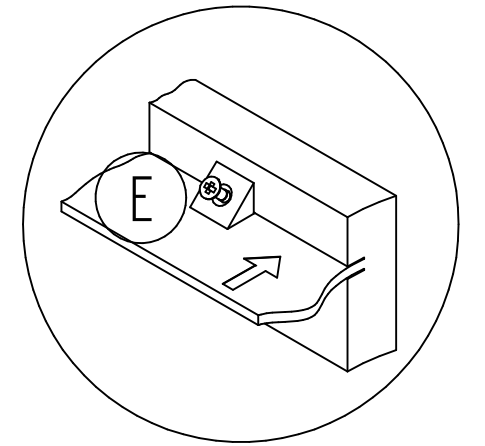
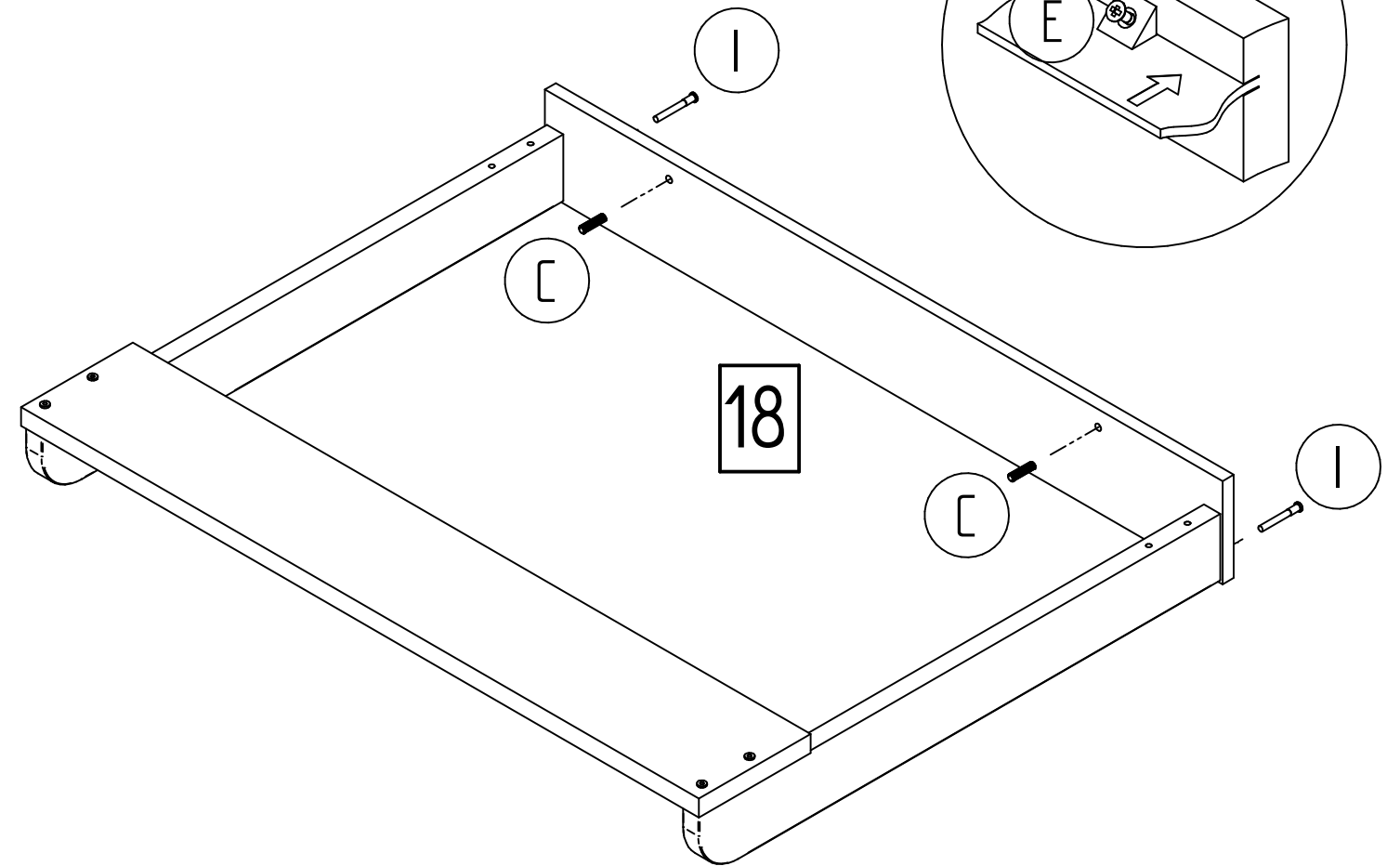
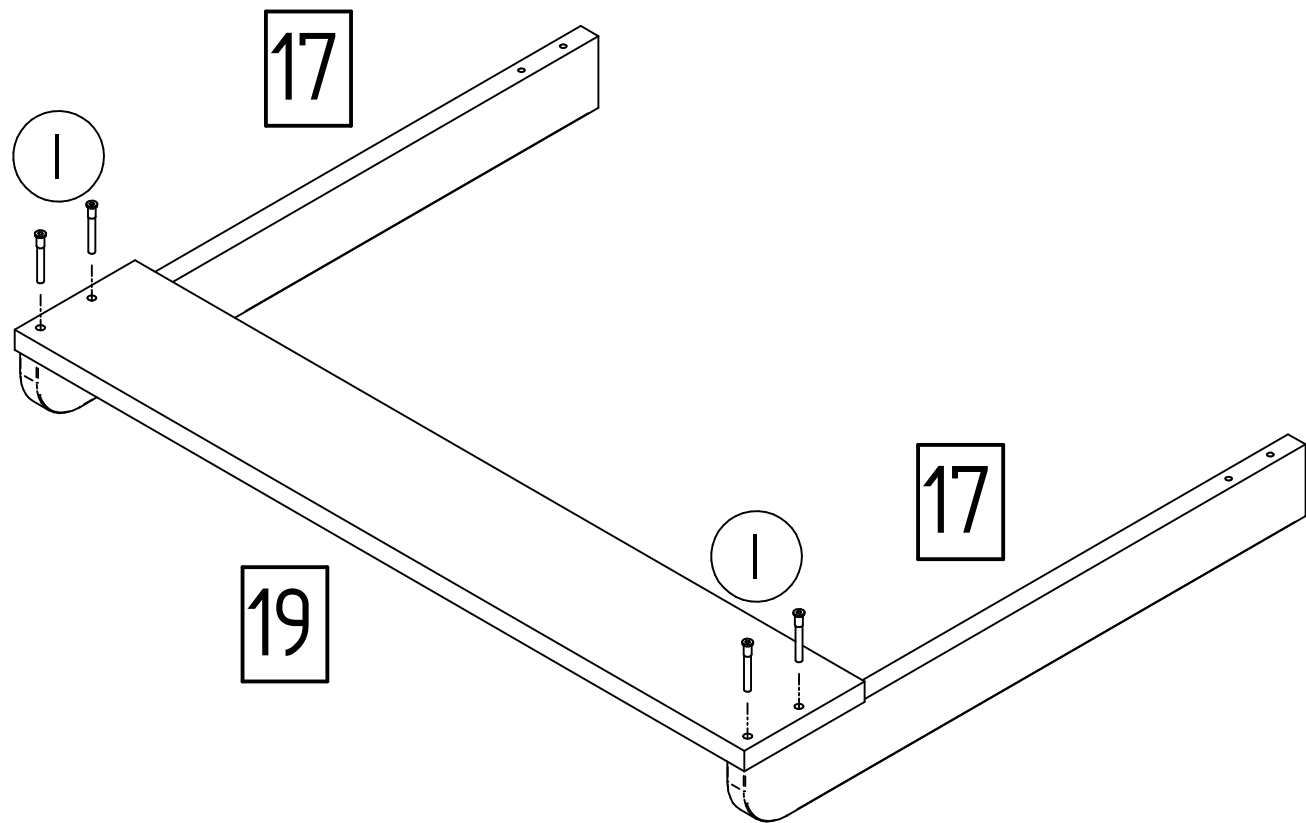
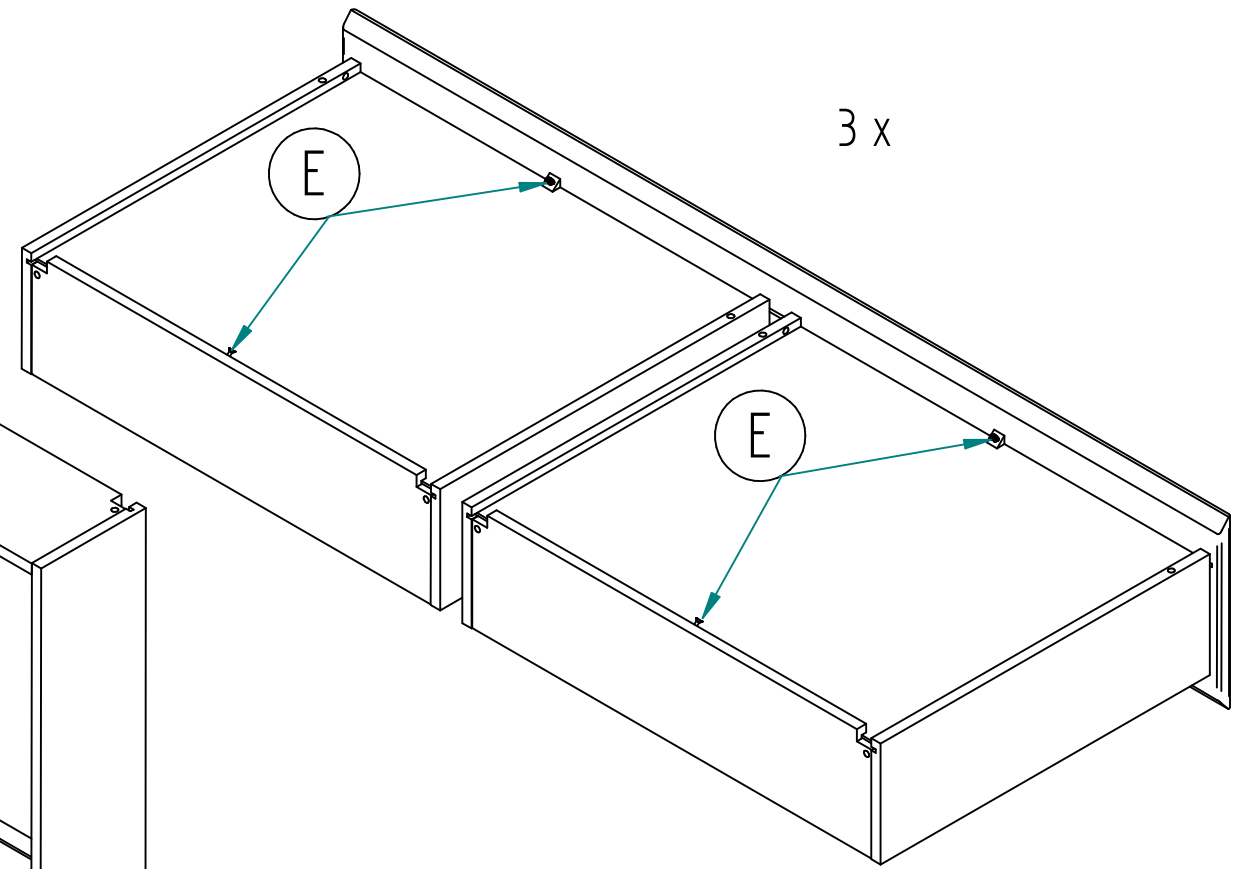
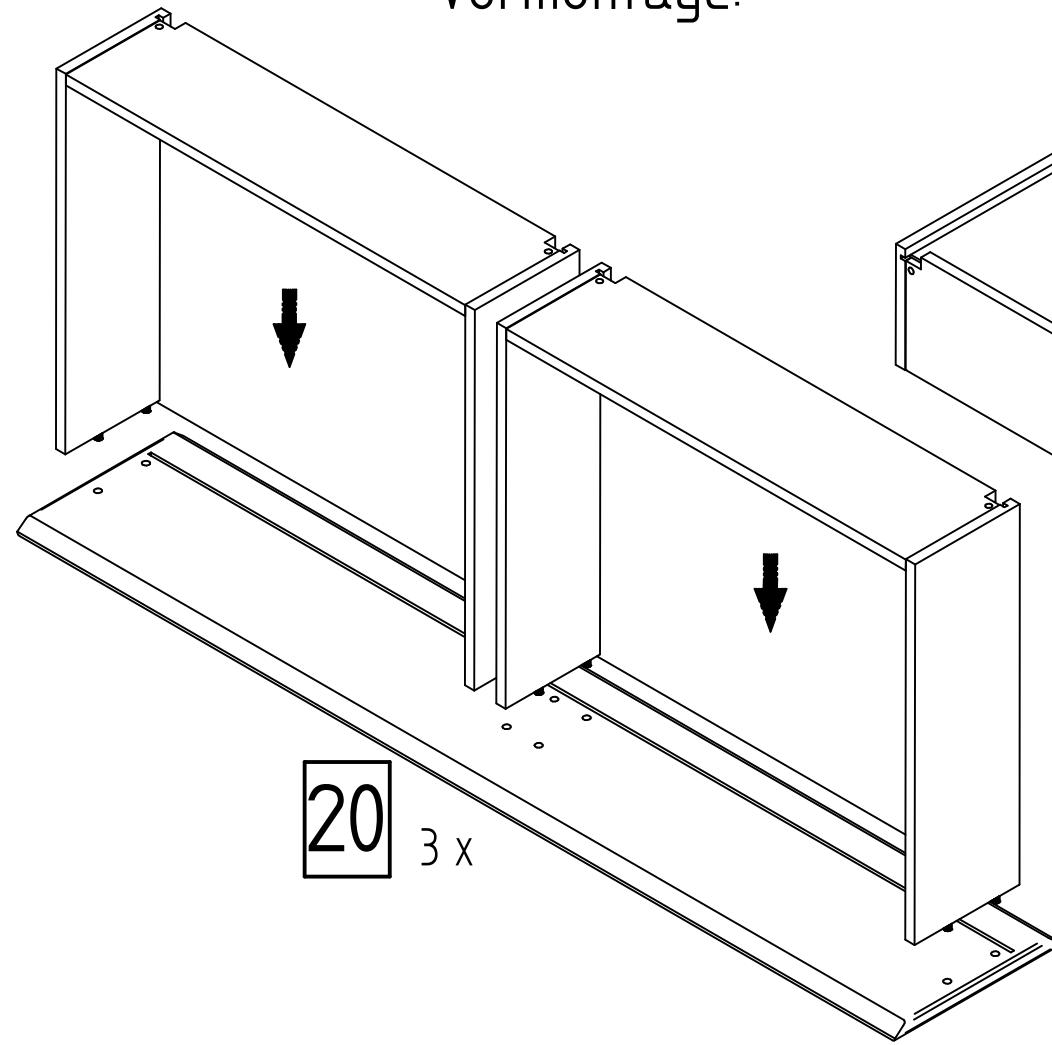
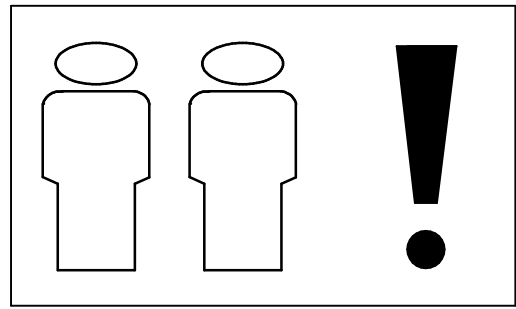
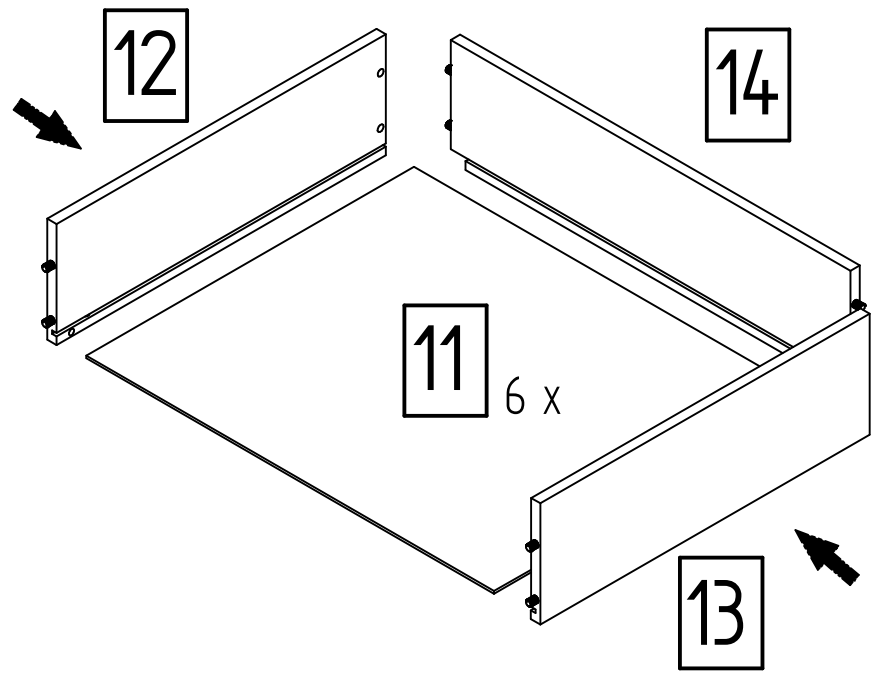

Zusammenbau:

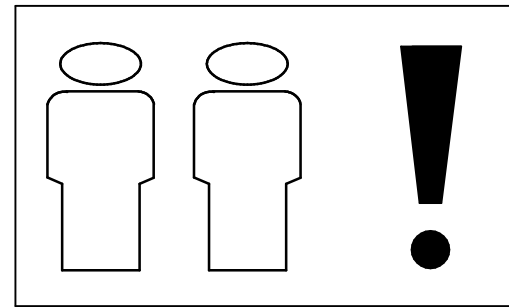
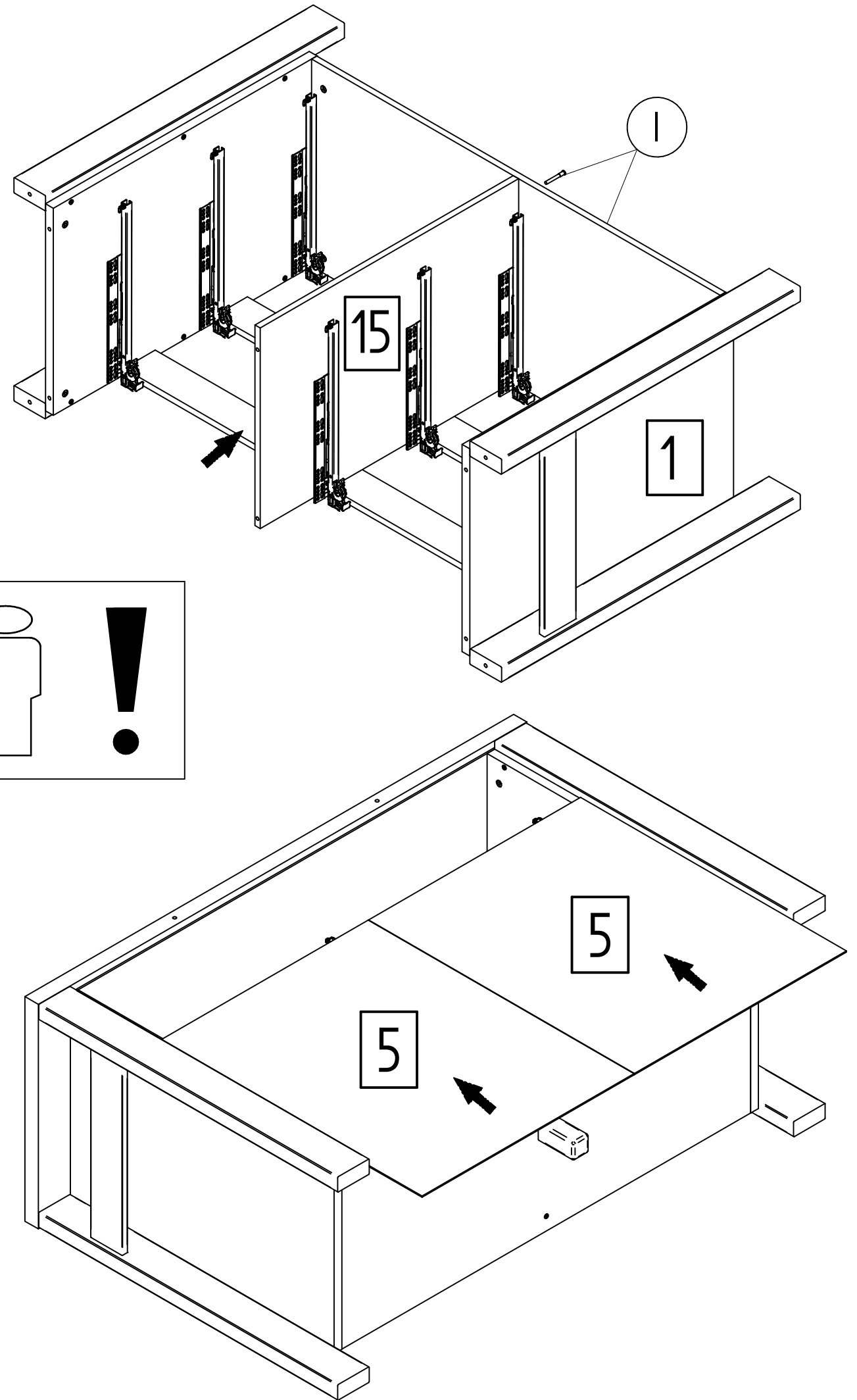
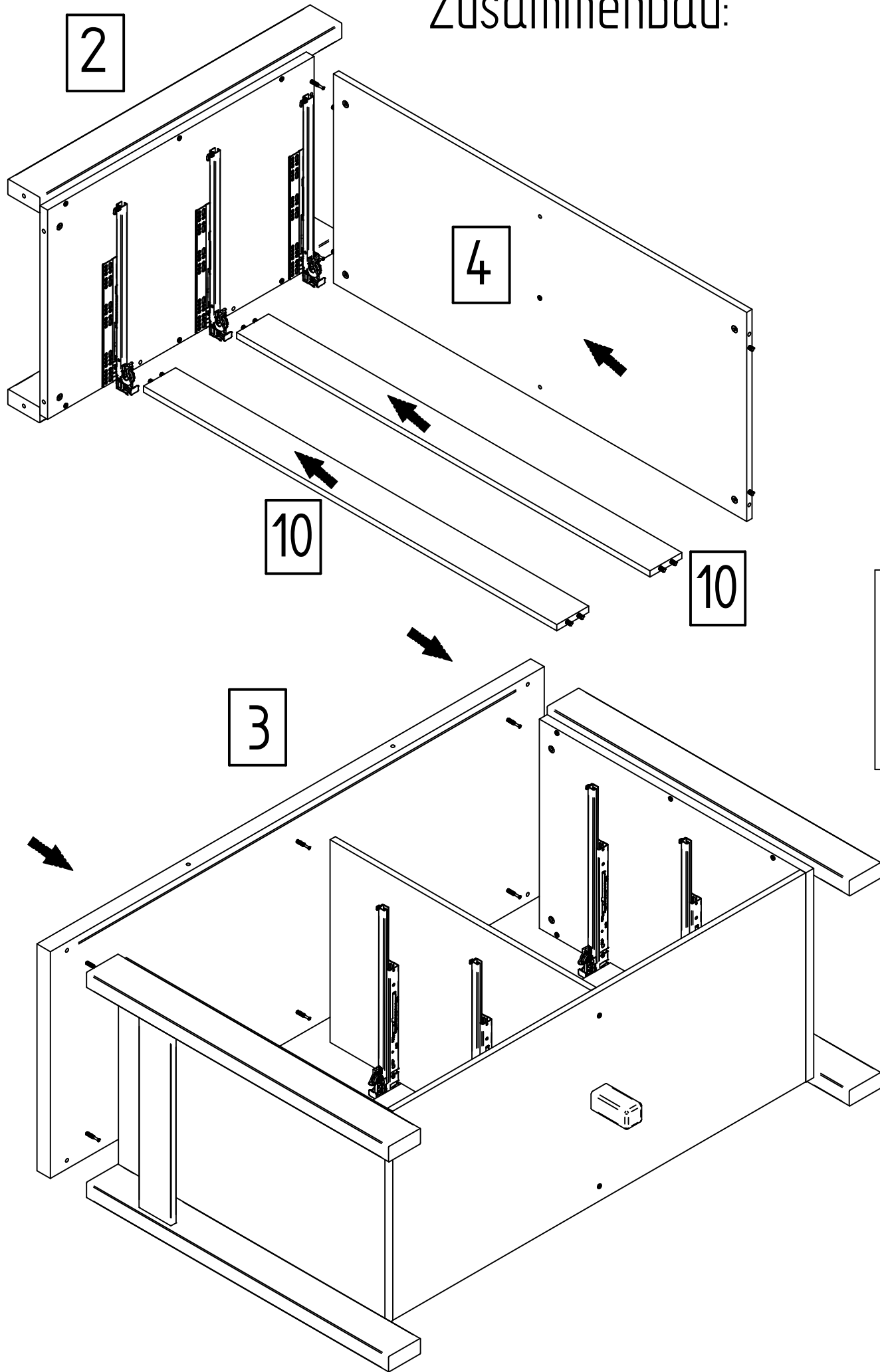



# Zusammenbau:

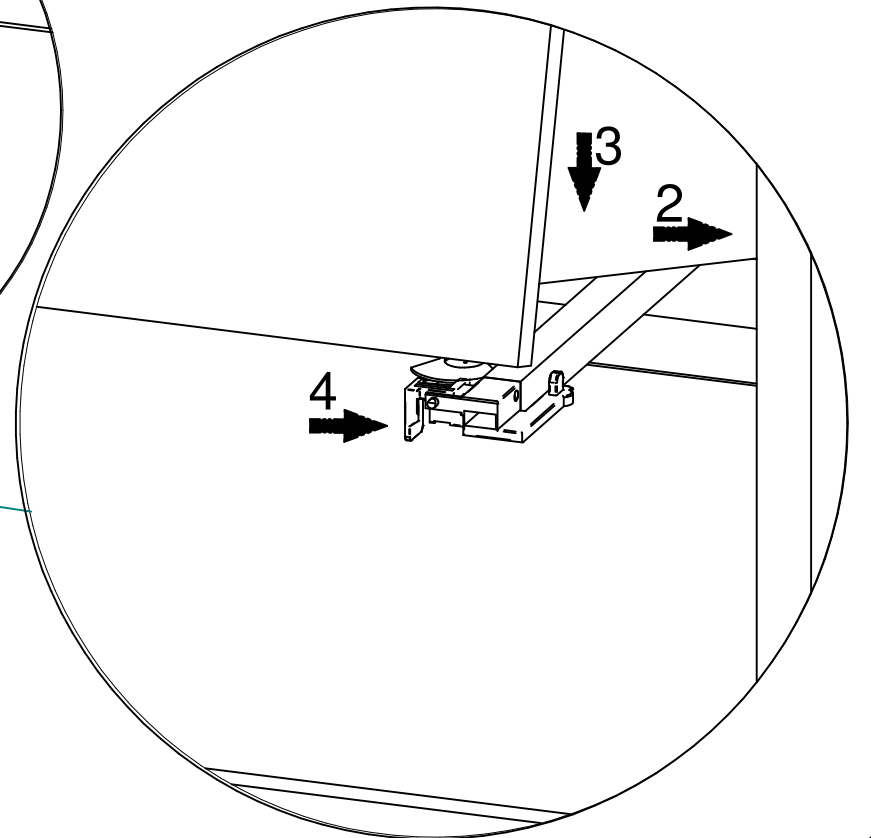
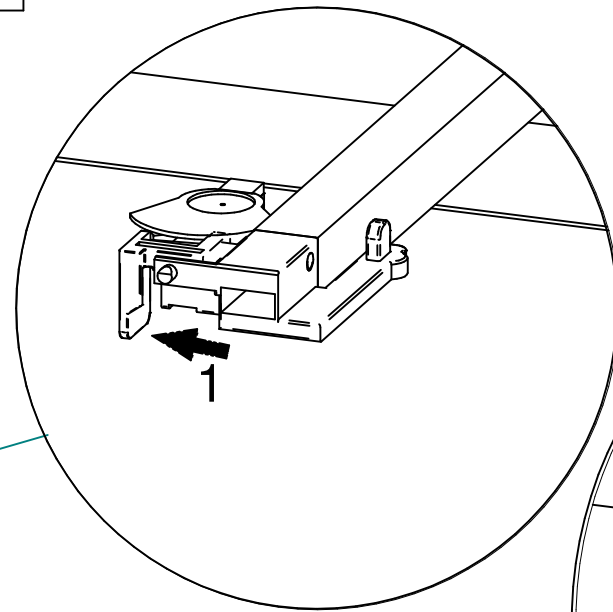
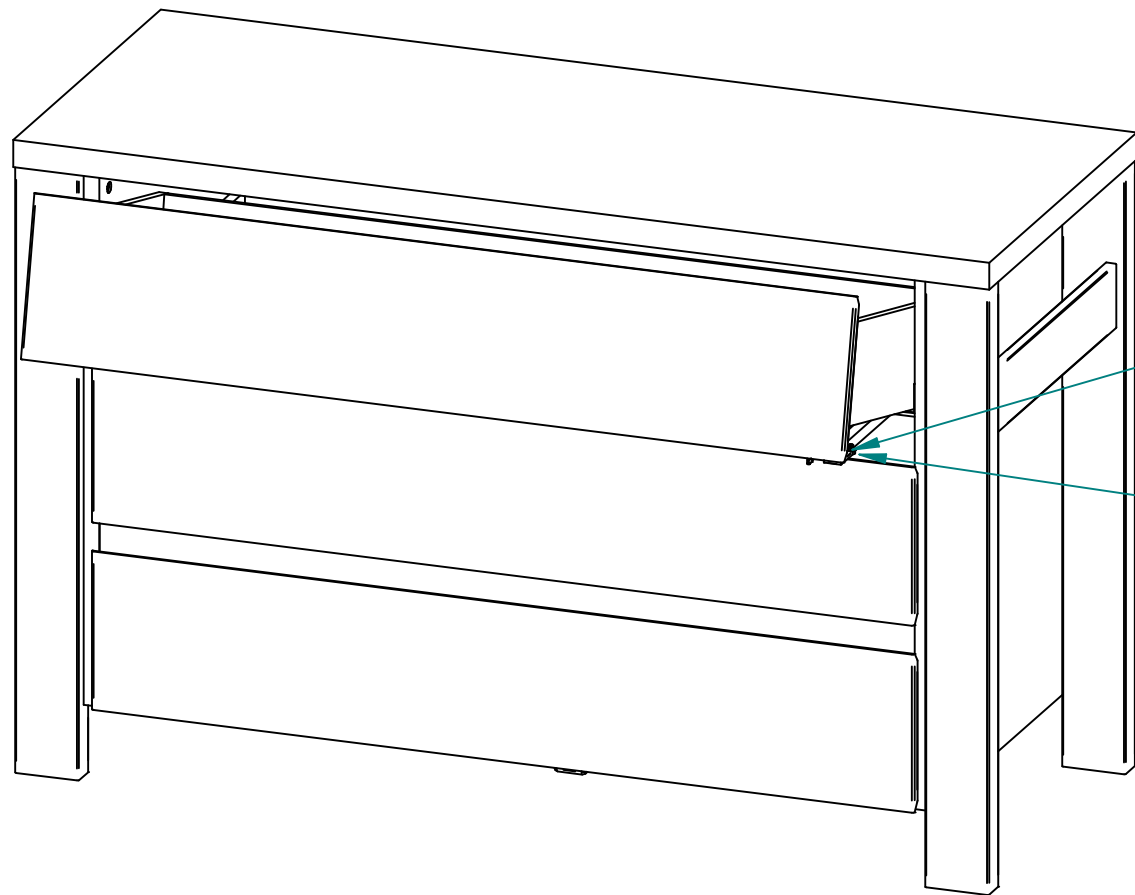
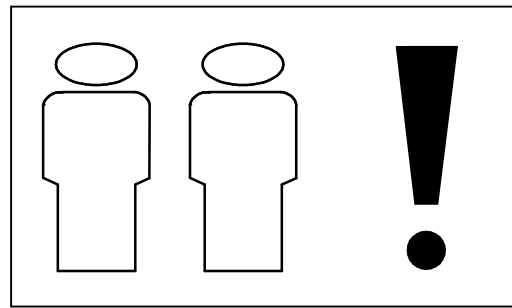
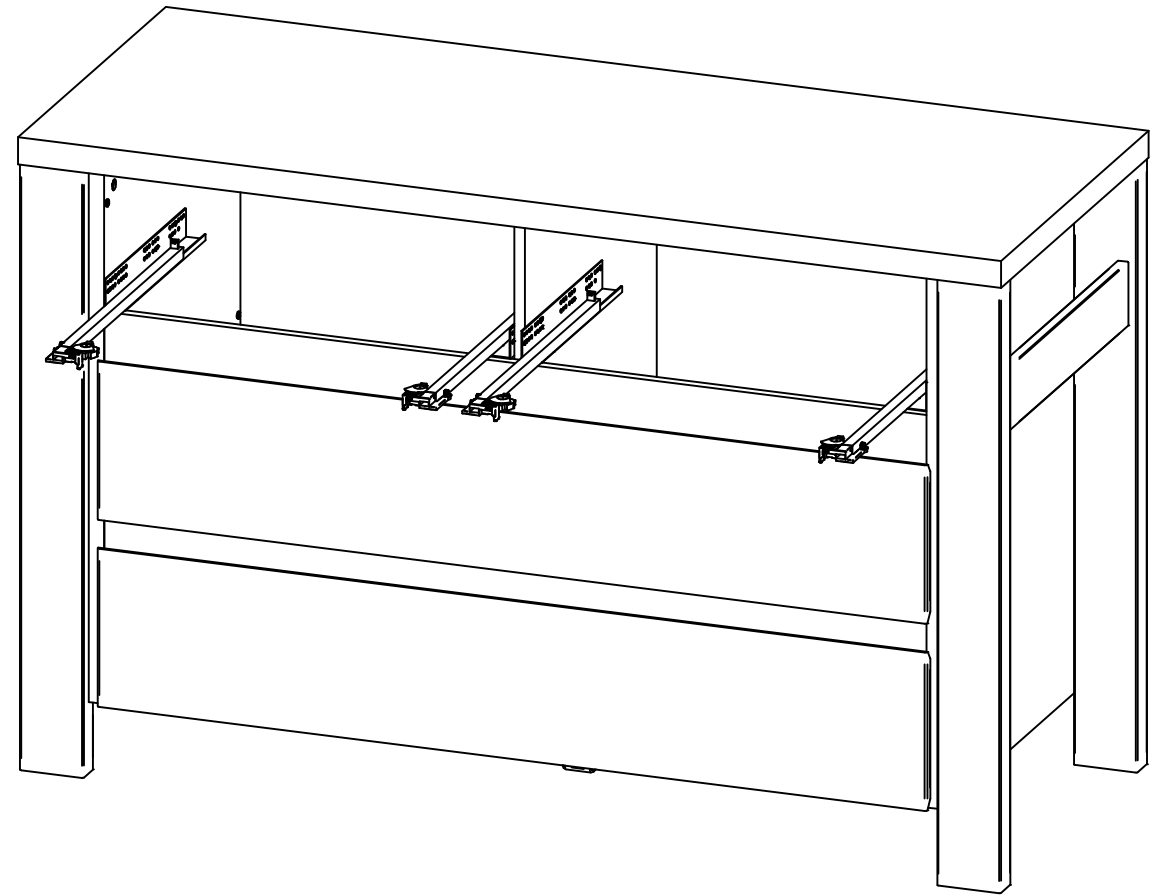
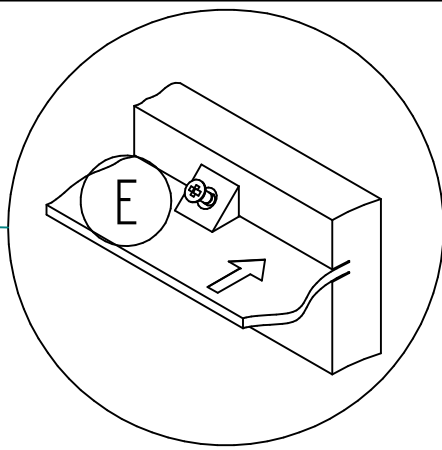
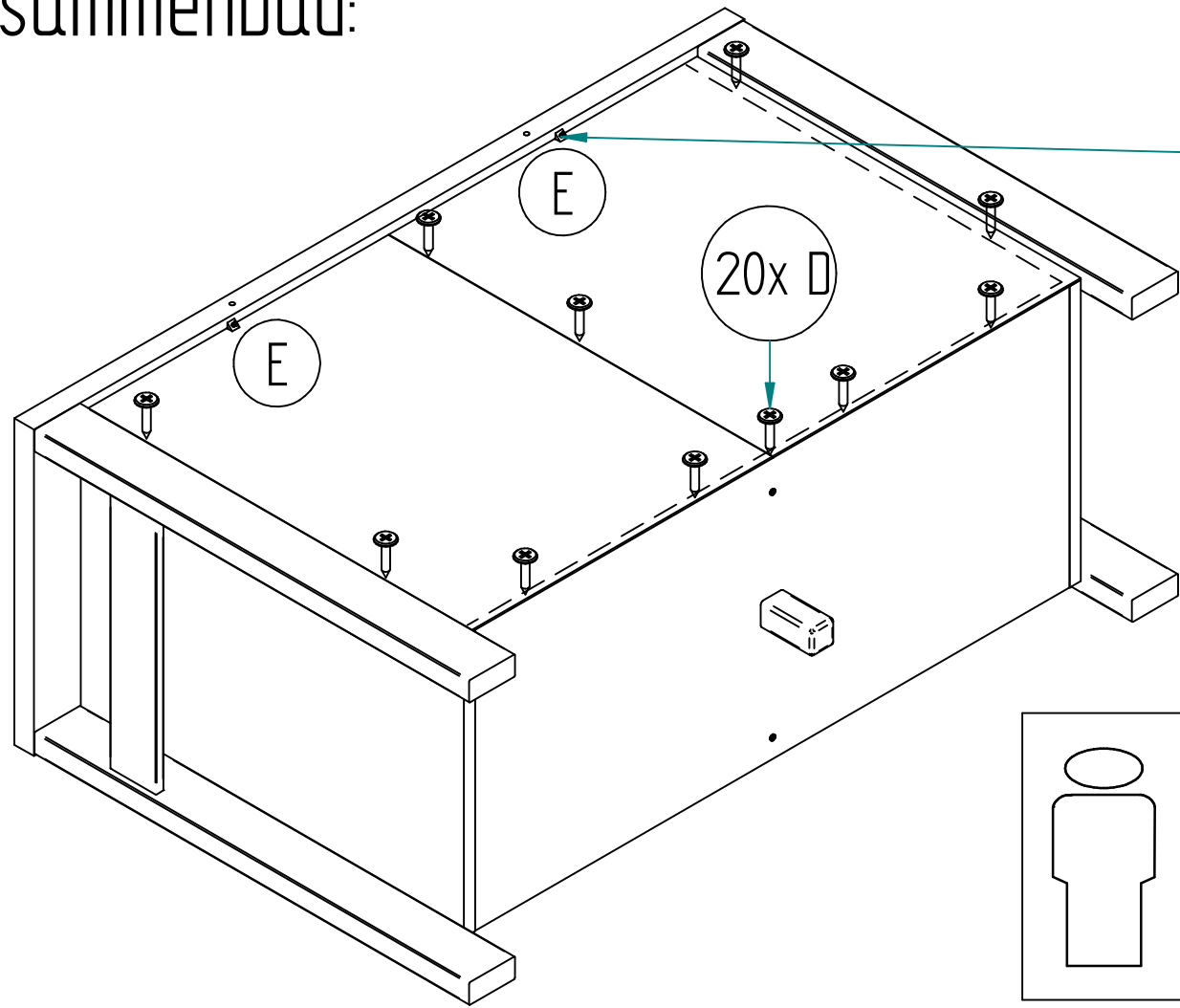

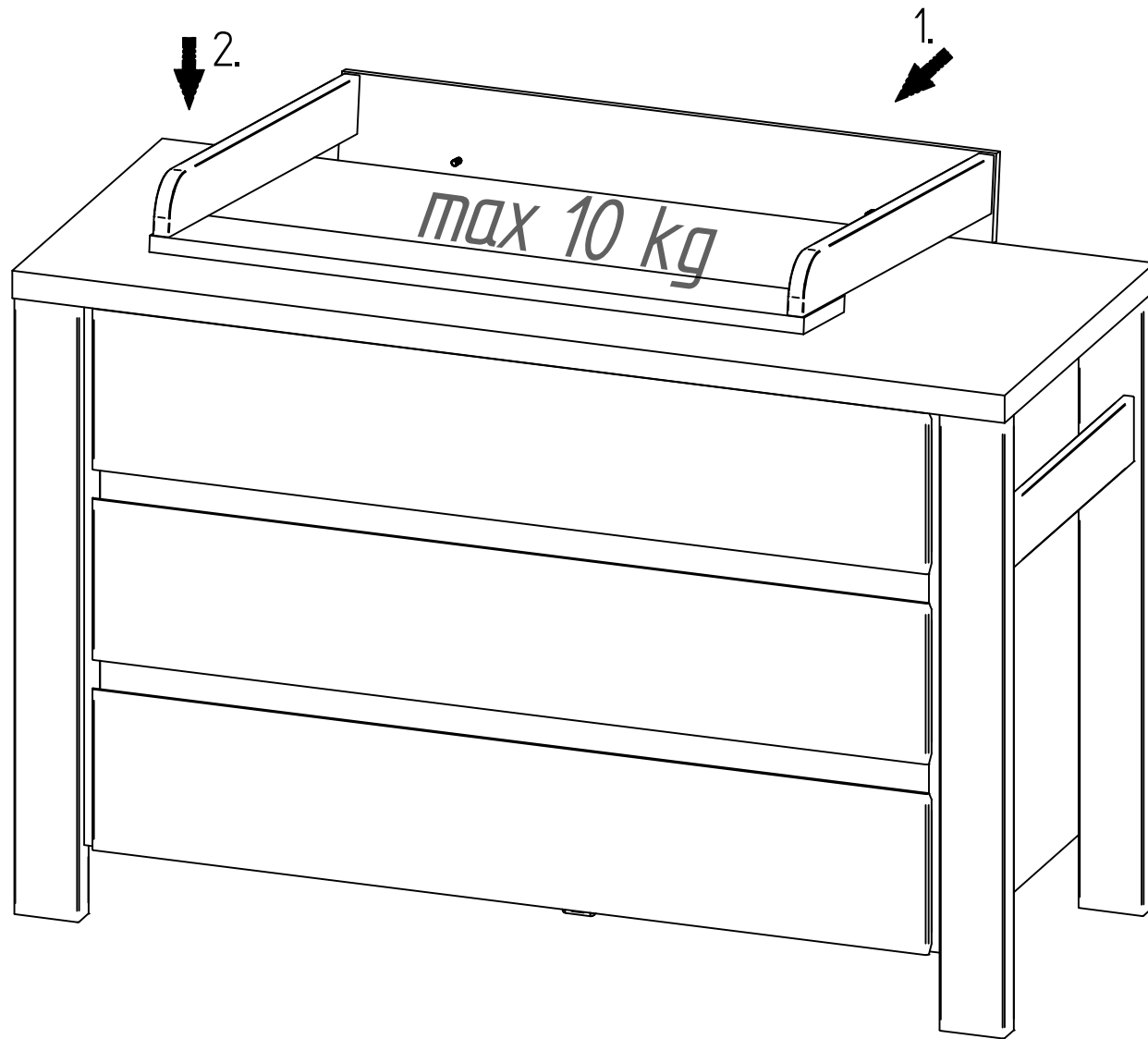

### Achtung !

Wird die Wickelkommode an der Wand befestigt , muss das Montage material der Beschaffenheit der Wand entsprechen !

### Attention !

If the baby changing table is attached to the wall the assembly material has to be appropriate for the composition of the wall !

### Attention !

Si la table à langer est attachée au mur il doit être approprié le matériel d'assemblage pour la composition du mur !

### Attenzione !

Si il fasciatoio é fortificato al muro il deve essere appropriato il materiale di montaggio alla composizione del muro !

... weitere Infos über unsere Produkte unter  
... plus d'informations sur nos produits sous  
... altre informazione degli prodotti di noi sotto

[www.schardt.com](http://www.schardt.com)

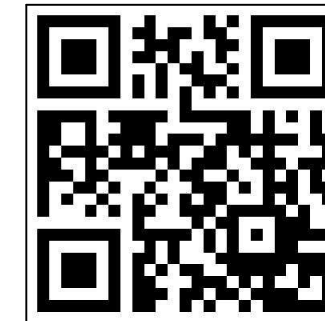

**Schardt GmbH & Co. KG**  
Am Riegel 15  
96268 Mitwitz  
Tel. 09266/9907-0  
Fax 09266/9907-77  
E-Mail: [info@schardt.com](mailto:info@schardt.com)